

H-700 Series Bak-Chek® Control Stops and Replacement Parts (Available for 3/4" and 1" water supply inlet pipes)

Replaces H-600 and H-540 Series Control Stops

* Refer to page 5 for diagrams of our Stop Caps and page 6 for the components supplied in our Control Stop Repair Kits.

Control Stop and Replacement Parts

Part Number **Code Number**

H-700 Stop, chrome plated: Screw Driver Angle Stop with H-1010-A Vandal Resistant Cap

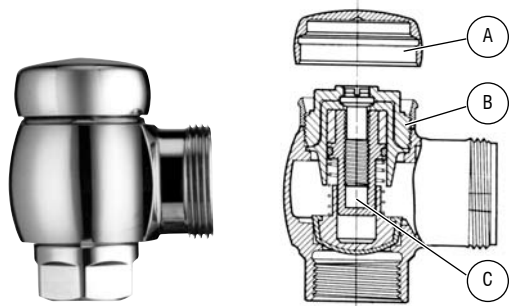

Complete Stops

3/4" NPTF inlet for adjustable tail	H-700-A	3308384
1" NPTF inlet for adjustable tail	H-700-A	3308386
3/4" NPTF inlet for ground joint tail	H-700-AG	3308385
1" NPTF inlet for ground joint tail	H-700-AG	3308387
1" Whitworth inlet for adjustable tail	H-700-AW	3308388

Repair Parts

A Vandal Resistant Cap*, chrome plated	H-1010-A	3308791
B Bonnet, chrome plated	H-622	0308612
C Control Stop Repair Kit*	H-541-ASD	3308853

H-710 Stop, chrome plated: Screw Driver Angle Stop with H-573 Locking Vandal Resistant Cap

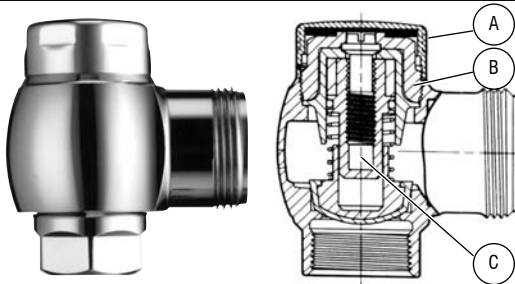

Complete Stops

3/4" NPTF inlet for adjustable tail	H-710-A	0388025
1" NPTF inlet for adjustable tail	H-710-A	0388022
3/4" NPTF inlet for ground joint tail	H-710-AG	0388026
1" NPTF inlet for ground joint tail	H-710-AG	0388024
1" Whitworth inlet for adjustable tail	H-710-AW	0388037
1" BSP British Standard Pipe inlet for adjustable tail	H-710-AAR	0388062
1" NPTF inlet for adjustable tail (Naval brass)	NH-710-A	0388043
3/4" NPTF inlet for ground joint tail (Naval brass)	NH-710-AG	0388048
1" NPTF inlet for ground joint tail (Naval brass)	NH-710-AG	0388058
1" Whitworth inlet for adjustable tail (Naval brass)	NH-710-AW	0388042
1" Whitworth inlet for ground joint tail (Naval brass)	NH-710-AW	0388045
1" NPSM inlet for ground joint tail (Naval brass)	NH-710-AGS	0388044

Repair Parts

A Locking Vandal Resistant Cap*, chrome plated	H-573-A	3308840
B Bonnet, chrome plated	H-622	0308612
C Control Stop Repair Kit*	H-541-ASD	3308853

H-720 Stop, chrome plated: Screw Driver Angle Stop with H-574 Short bumper Cap (-YO Variation)

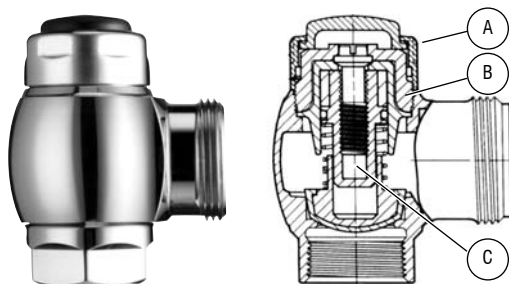

Complete Stops

1" NPTF inlet for adjustable tail	H-720-A	0388034
1" NPTF inlet for ground joint tail	H-720-AG	0388033
1" Whitworth inlet for adjustable tail	H-720-AW	0388038

Repair Parts

A Stop Cap with Seat Bumper*, chrome plated	H-574	3308866
B Bonnet, chrome plated	H-622	0308612
C Control Stop Repair Kit*	H-541-ASD	3308853

H-725 Stop, chrome plated: Screw Driver Angle Stop with H-576 Extended Bumper Cap (-YG Variation)

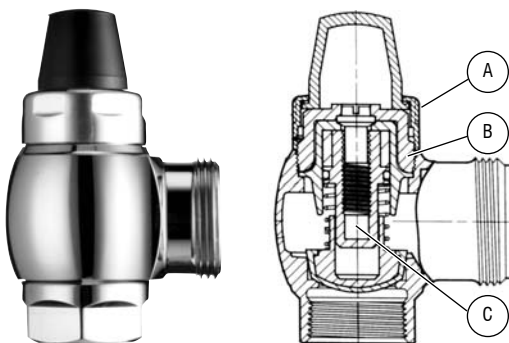

Complete Stops

1" NPTF inlet for adjustable tail	H-725-A	0388035
1" NPTF inlet for ground joint tail	H-725-AG	0388057
1" Whitworth inlet for adjustable tail	H-725-AW	0388039
1" Whitworth inlet for ground joint tail (Naval brass)	NH-725-AGW	0388047

Repair Parts

A Stop Cap with Extended Seat Bumper*, chrome plated	H-576	3308867
B Bonnet, chrome plated	H-622	0308612
C Control Stop Repair Kit*	H-541-ASD	3308853