

Viega MegaPress and MegaPressG Fitting System Installation Manual



viega



An international company with a national commitment

For over 110 years, Viega has been a trusted name in the piping and tubing system manufacturing business. We research, develop and produce complete system solutions for contractors in the plumbing, industrial, shipbuilding, radiant heating and snow melting installation business. Each of our systems is developed in-house and tested under stringent quality control conditions to guarantee safe and efficient operation. Through innovative techniques and sophisticated technologies Viega has become the worldwide industry leader.

Today, Viega products extend worldwide. Our network of sales experts and wholesale distributors can meet your needs. The products we deliver are of the finest quality, offered at a competitive price. Our goal is to remain in the forefront of the plumbing industry.

Call 1-800-976-9819 for your local District Manager and wholesale location.

Welcome

By choosing a Viega MegaPress and/or MegaPressG fitting system, you have joined the ranks of professional installers across the country that believe there is no substitute for quality. Viega has a history of bringing high quality and

innovative technology to the world. Our engineers research and develop complete systems that provide you with the most effective and easy-to-use products available.

Historically, black steel piping systems have been installed by either threading the pipe and installing threaded fittings or welding fittings to the pipe. Both methods are labor intensive jobs which produce inconsistent pipe joints. These methods of pipe joining are not only dependent on the installer's skill level, but also rely on machinery which is cumbersome, expensive to maintain.

The Viega MegaPress systems eliminate the need for cumbersome equipment, oils, fire watches and burn permits.

Viega press technology ensures the installer a consistent, reliable joining method for black steel pipe. The Viega MegaPress systems provide added benefit by joining black steel pipe without flames or threads and making connections in seconds, keeping projects on time and within budget.

Viega MegaPress systems also incorporate the Smart Connect feature. This patented feature ensures the leakage of liquids and/or gases past the sealing element of unpressed fittings during pressure testing. The Smart Connect feature is removed during the pressing process, creating a leak-free, permanent mechanical joint connection.

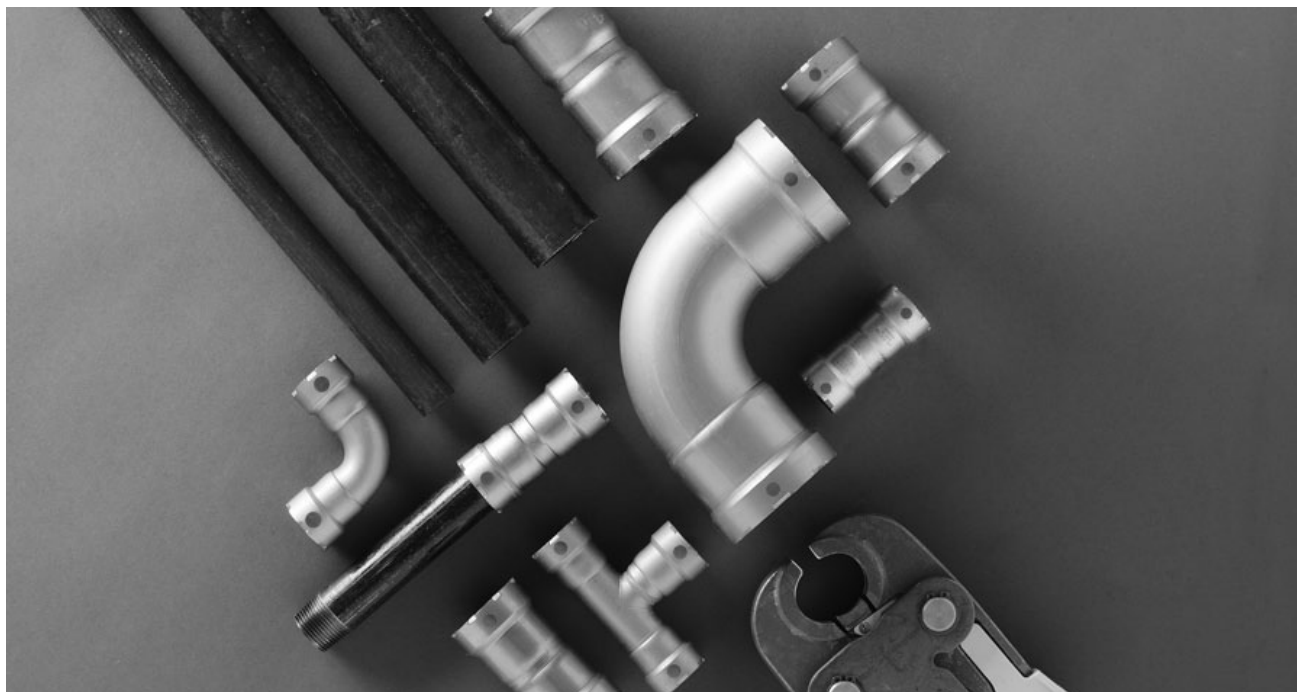



1 System Description

- 1.1 Viega MegaPress.....4
 - 1.1.1 Approvals and Certifications.....4
 - 1.1.2 Codes.....4
- 1.2 Viega MegaPressG.....4
 - 1.2.1 Approvals and Certifications.....4
 - 1.2.2 Codes.....4
- 1.3 Fitting Description.....4
 - 1.3.1 Smart Connect Feature.....5
 - 1.3.2 Testing.....5
 - 1.3.3 Sealing Elements.....5
 - 1.3.4 Fitting Markings.....6
- 1.4 Applications.....6

2 Tools

- 2.1 Tools.....7
- 2.2 Pressing Tools.....7

3 General Installation Instructions

- 3.1 Pipe Selection.....8
- 3.2 Handling Instructions.....8
- 3.3 Pipe Preparation.....8
- 3.4 Pressing Requirements.....8
 - 3.4.1 Minimum Distance Between Fittings.....8
 - 3.4.2 Pressing in Tight Quarters.....9
 - 3.4.3 Minimal Space Requirements for the Press Fitting Process in Front of and Behind Components.....9
 - 3.4.4 Pressing with Ring and Actuator in Tight Quarters.....10
- 3.5 Welding Requirements.....11
 - 3.5.1 Welding Adjacent to Viega MegaPress Fittings.....11
 - 3.5.2 Welding in Line with Viega MegaPress Fittings.....11
- 3.6 General Installation Requirements.....11
 - 3.6.1 Expansion.....11
 - 3.6.2 Electrical Bonding.....11
 - 3.6.3 Piping Exposed to Freezing Temperatures.....11
 - 3.6.4 Corrosion Protection.....11
 - 3.6.5 Concealed Spaces.....11
 - 3.6.6 Underground Installations.....11
 - 3.6.7 Pressure Testing.....11
 - 3.6.8 Transition Connections.....11
 - 3.6.9 Pipe Hangers.....12
- 3.7 Viega MegaPress and MegaPressG Installation Requirements.....12
 - 3.7.1 Rotating a Pressed Fitting.....12
 - 3.7.2 Deflection.....12
- 3.8 Identification.....12
- 3.9 Viega MegaPress 1/2" - 2" Installation.....13

4 Warranty

1 System Description

The Viega MegaPress and MegaPressG fitting systems are the state of the art IPS press fitting systems that provide an economical and reliable installation of schedule 5 to schedule 40 ASTM A53, A135 and A795 steel pipes. Viega MegaPress and MegaPressG fittings are available in size ranges from 1/2" to 2" and provide a fast, reliable, consistent joining method.

Our products are the result of decades of experience in manufacturing press fittings. The Viega MegaPress and MegaPressG fitting systems are offered in configurations which allow for the installation of the vast majority of black steel piping applications in the residential, commercial and industrial markets.

Viega MegaPress and MegaPressG fitting systems require no threading or welding, and thus pose no fire hazard, which is particularly important in restoration or retrofit work. The press fittings are installed with the system pressing tools (a battery powered or corded pressing tool).

The advantages of installing Viega MegaPress and MegaPressG fitting systems include:

- Most labor savings
- Lowest overall installed cost
- Proven joining technology
- Technical field support
- One tool for gas & water fittings
- No special certification required

1.1 Viega MegaPress

Viega MegaPress 1/2" - 2" fittings feature an EPDM sealing element suitable for the following applications:

- Hydronic Heating
- Chilled Water
- Compressed Air
- Low Pressure Steam
- Fire Sprinkler Systems

For more information, see Table 1.1 (page 6).

1.1.1 Approvals and Certifications

- TSSA

1.1.2 Codes

- ASME B31, 31.1, 31.3, 31.9
- ICC International Plumbing Code
- ICC International Mechanical Code
- UPC Uniform Plumbing Code
- UMC Uniform Mechanical Code
- PHCC National standard plumbing code
- NFPA 13,13D and 13R

1.2 Viega MegaPressG

Viega MegaPressG 1/2" - 2" fittings have a factory installed HNBR sealing element suitable for the following applications.

- Natural Gas
- Liquid Propane Gas
- Diesel Fuel

For more information, see Table 1.1 (page 6).

1.2.1 Approvals and Certifications

Viega MegaPressG fittings have been listed for use in schedule 40 fuel gas piping systems in above and below ground applications by CSA.

- CSA LC-4

1.2.2 Codes

The major codes and standards regulating fuel gas piping systems include:

- NFPA 54/Z223.1 National Fuel Gas Code
- ICC International Plumbing Code
- ICC International Mechanical Code
- IAPMO Uniform Plumbing Code

All of these codes regulate both natural gas and liquid propane gas piping systems. ASTM A53 schedule 40 pipe is permitted for fuel gas piping systems in the National Fuel Gas Code (NFPA 54), the International Fuel Gas Code, or the Uniform Plumbing Code.

Other codes include:

- NFPA 58 Liquefied Petroleum Gas Code
- UPC Chapter 12 Fuel Piping
- NFPA 30 Flammable and Combustible Liquids Code
- NFPA 30A Code for Motor Fuel Dispensing Facilities and Repair Garages
- NFPA 31 Standard for the Installation of Oil-Burning Equipment

Note: All systems must be installed per local code requirements.

1.3 Fitting Description

Viega MegaPress and MegaPressG fittings are constructed of carbon steel with a corrosion resistant coating.

Viega MegaPress and MegaPressG fittings contain a stainless steel grip ring and 304 stainless steel separator ring as shown in Figure 1.1. The grip ring is a 420 stainless steel ring with bidirectional teeth, which grip the pipe and ensure that the fitting is locked securely to the piping.

The 304 stainless steel separator ring ensures that the sealing element and grip ring perform at maximum capacity by providing a positive physical separation.

Press jaws and actuator rings are available for various dimensions. Their constant compression always produces a positive, non-detachable, mechanical joint, which ensures a permanent connection.

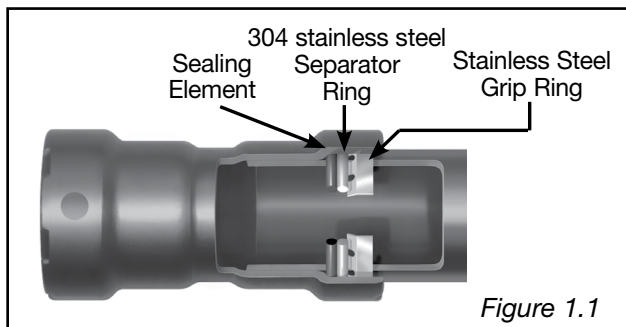

Figure 1.1

1.3.1 Smart Connect Feature

In Viega MegaPress and MegaPressG 1/2" to 2" dimensions, the Smart Connect feature assures leakage of liquids and/ or gases from inside the system past the sealing element of an UNPRESSED connection. The function of this feature is to provide the installer quick and easy identification of connections that have not been pressed prior to putting the system into operation.

Press systems without the Smart Connect feature may not leak initially; however, they may unseat during future system operation. The Smart Connect feature is designed to protect from this potential risk. See Figure 1.2

The Smart Connect feature is a quick and easy way for installers to identify connections that need pressing. Testing for leaks using the Smart Connect feature is not a replacement for testing to the requirements of local codes or standards.

1.3.2 Testing

All system testing shall be carried out in accordance to the local code or authority having jurisdiction. Viega recommends air testing of gas systems to be a minimum of 1/2 psi.

1.3.3 Sealing Elements

Viega MegaPress and MegaPressG fitting systems are available with the following factory-installed sealing elements:

Viega MegaPress EPDM Sealing Element

Operating temperature: 0°F to 250°F (-18°C to 120°C)

This sealing element is used mainly in the applications of hydronic heating, chilled water and fire sprinkler installations. EPDM, or ethylene-propylene-diene monomer, is shiny black in color. The EPDM sealing element is a synthetically manufactured and peroxidically cross-linked general purpose elastomer with a wide range of applications.

The EPDM sealing element possesses excellent resistance to aging, ozone, sunlight, weathering, environmental influences, alkalis and most alkaline solutions and chemicals used in a broad range of applications.

Viega MegaPressG HNBR Sealing Element

Operating temperature: -40°F to 180°F (-40°C to 82°C)

This sealing element is used mainly for fuel gas applications (not in the liquid state). HNBR, or Hydrogenated Nitrile Butadiene Rubber, is yellow in color for easy identification.

With its excellent performance for the most demanding of applications, HNBR is the ideal choice for applications needing excellent physical properties, as well as oil and/or chemical resistance.

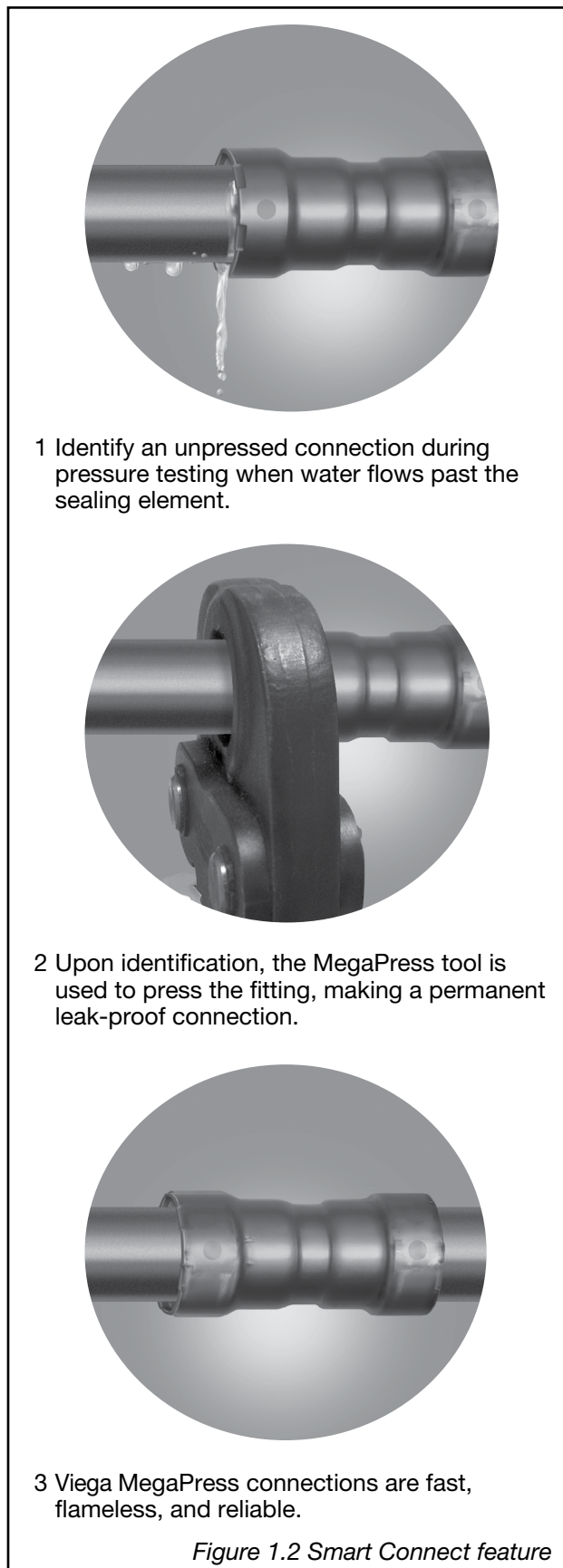

1 Identify an unpressed connection during pressure testing when water flows past the sealing element.

2 Upon identification, the MegaPress tool is used to press the fitting, making a permanent leak-proof connection.

3 Viega MegaPress connections are fast, flameless, and reliable.

Figure 1.2 Smart Connect feature

1.3.4 Fitting Markings

Markings on Viega MegaPress fittings include:

- Green Dot: EPDM sealing element and Smart Connect feature
- Size of fitting
- Manufacture Name
- Manufacture Date Code

Markings on Viega MegaPressG fittings include:

- Yellow Dot: HNBR sealing element and Smart Connect feature
- CSA: Indicates certification to ANSI/CSA LC4
- Yellow rectangle: Identifies Viega MegaPressG fitting as a certified gas or fuel oil fitting

- 125G: Identifies the CSA maximum pressure rating of the fitting for fuel oil or gas applications
- Size of fitting
- Manufacture Name
- Manufacture Date Code

1.4 Applications

Listed below are common applications approved by Viega for Viega MegaPress and MegaPressG fitting systems. See Table 1.1.

Types of Service	System Operating Conditions			MegaPress	MegaPressG
	Comments	Pressure	Temperature	EPDM	HNBR
Fluids/Water					
Chilled Water	Ethylene Glycol Propylene Glycol	200 psi	Down to -4°F	√	
Hydronic Heating	Ethylene Glycol Propylene Glycol	200 psi	0°F - 250°F	√	
Fire Sprinkler		175 psi		√	
Low Pressure Steam	with inhibitor	Up to 15 psi	max. 248°F	√	
Oil and Lubricant					
Heating Fuel Oil		125 psi	-40°F - 180°F Ambient		√
Diesel Fuel	Compliant with NFPA 30 and 30A	125 psi			√
Gases					
Natural Gas, LP Gas and Fuel Oil	ANSI/CSA LC4 -40°F - 180°F 125 PSI Max.	125 psi max.	-40°F - 180°F Ambient		√
Compressed Air	Oil Concentrate < 25mg/m3	200 psi		√	√
	Oil Concentrate > 25mg/m3	200 psi			√
Vacuum		Max. 29.2in Hg		√	√
Oxygen Non-medical	Keep oil and fat free / non liquid	140 psi (200 psi only HNBR)	Up to 140°F	√	√
1. Consult the Viega Technical Support Department for information on applications not listed, and applications outside the temperature and pressure ranges listed above.					
2. All systems are recommended to be clearly labeled with the fluid or gas being conveyed. For further information please see the Viega technical bulletin TB-PIPELABELING.					

Table 1.1 Approved Applications

2.1 Tools

Viega recommends RIDGID press tools, MegaPress and MegaPressG jaws and ring sets and RIDGID pipe preparation tools manufactured and sold by Ridge Tool Company for use with Viega Systems.

Viega MegaPress and MegaPressG products carry a warranty against defects in material and workmanship. The RIDGID lifetime warranty applies to tools, jaws and press rings from The Ridge Tool Company. For more information, contact Ridge Tool Company at 1-888-743-4333 or visit www.RIDGID.com.

2.2 Pressing Tools

The following RIDGID pressing tools are available for the Viega MegaPress and MegaPressG pressing system:

- RP330-B Battery Powered Press Tool
- RP330-C Corded Press Tool
- RP320-E
- RP400-E



MegaPress Pipe Preparation Tool
 RP37993 1/2" - 1"
 RP37988 1 1/4" - 2"



RP 330-B
 1/2" - 2"



V2 Actuator and MegaPress Jaws
 Jaws 1/2" - 1"
 Ring Set 1-1/4" - 2"



RP 330-C
 1/2" - 2"

RIDGID® is a registered trademark of the Ridge Tool Company

3 General Installation Instructions

3.1 Pipe Selection

Viega MegaPress and MegaPressG 1/2" - 2" fittings are compatible with black ASTM A53, A135 and A795 black steel pipe.

3.2 Handling Instructions

Viega MegaPress and MegaPressG components shall be free from dirt, debris, or items that may interfere with the sealing element and the press connection. Pipe shall be cut using a pipe cutter or metal saw. It is not acceptable to cut the pipe with an abrasive cutting wheel or torch.

3.3 Pipe Preparation

Viega MegaPress and MegaPressG fittings are designed for use with ASTM A53, A135 and A795 black steel pipe, schedule 5 to schedule 40. In general there are three pipe types typically used in black steel applications:

Painted black steel pipe

Painted black steel pipe shall be inspected for excessive paint runs. Excessive paint runs shall be smoothed using a fine grit sand paper or the MegaPress Pipe Prep tool.

Painted and lacquered black steel pipe

Due to the inconsistency of black steel pipe surfaces that are painted and lacquered, it is a requirement to smooth the pipe surface using a fine grit sand paper or the MegaPress Pipe Prep tool.

Epoxy coated black steel pipe

Due to the thickness of the coating applied to coated black steel pipe, it is necessary reduce the coating thickness with a fine grit sand paper to allow the installation of the Viega MegaPress or MegaPressG fitting.

Pipe surfaces for each type of pipe must be smooth, free of indentations, pits and deformations and must be clean and free of debris, rust, scale, paint, oil, grease.

It is not necessary to completely remove protective coatings or to expose the bare steel material.

Pipe ends are to be square and de-burred internally and externally. The pipe end shall be prepped to the proper insertion depth. See Table 3.1.

Pipe Size	Insertion Depth (in)	Insertion Depth (mm)
1/2"	1-1/16	27
3/4"	1-3/16	30
1"	1-3/8	35
1-1/4"	1-7/8	47
1-1/2"	1-7/8	48
2"	2	51

Table 3.1

To avoid leak paths, engraved or stamped pipe shall not be used with the Viega MegaPress or MegaPressG fitting system.

Engraving or stamping shall not be removed through use of a grinder or other tool.

Viega MegaPress and MegaPressG sealing elements, separator rings and grip rings are to be visually inspected prior to installation to ensure the seal is intact and properly located within the fitting. Viega MegaPress and MegaPressG sealing elements may not be removed or replaced.

The Viega MegaPress and MegaPressG fitting system does not require lubrication of the pipe or the fitting.

For further pipe preparation information, please refer to the Ridge Tool Company's Installation Manual.

3.4 Pressing Requirements

The following requirements must be considered when pressing Viega MegaPress and MegaPressG fittings.

3.4.1 Minimum Distance Between Fittings

Space between fittings must be provided for the proper operation of the press jaw or press ring (refer to chart below). Failure to provide this distance may result in an improper seal.

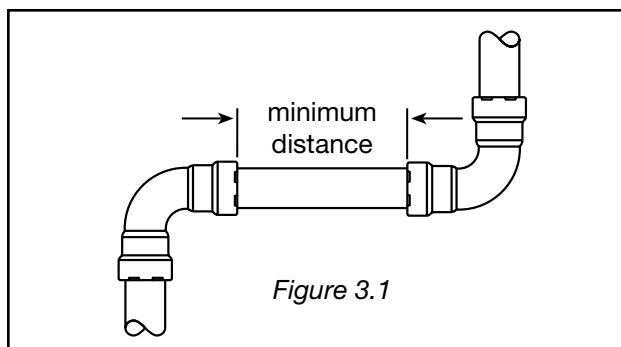

Figure 3.1

Minimum distance between two Viega MegaPress press connections 1/2" to 2"		
Pipe Diameter	Minimum Distance (mm)	Minimum Distance (in)
1/2"	5	3/16
3/4"	5	3/16
1"	5	3/16
1-1/4"	10	3/8
1-1/2"	10	3/8
2"	10	3/8

Table 3.2

3.4.2 Pressing in Tight Quarters

The minimum distance between piping, or the piping and the wall/ceiling construction, must be taken into consideration in the planning phase for a problem-free work process. The following figures illustrate the clearance requirements for the jaws and fittings and the procedure for pressing fittings in tight quarters.

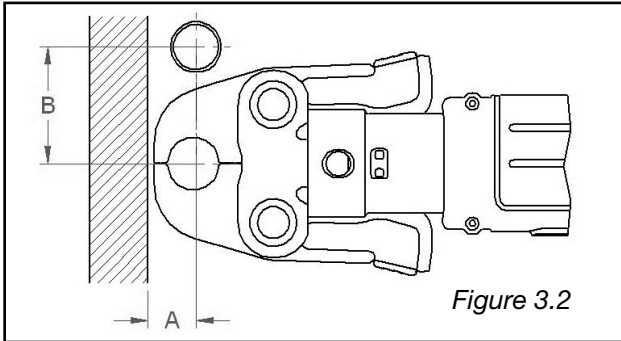

Figure 3.2

Pipe Diameter	A minimum		B minimum	
	in	mm	in	mm
1/2"	1	26	2-5/8	67
3/4"	1-1/4	32	3-1/8	79
1"	1-3/4	45	3-5/8	92

Table 3.3

Minimum distance requirements for press jaws between pipes and wall/floor structure.

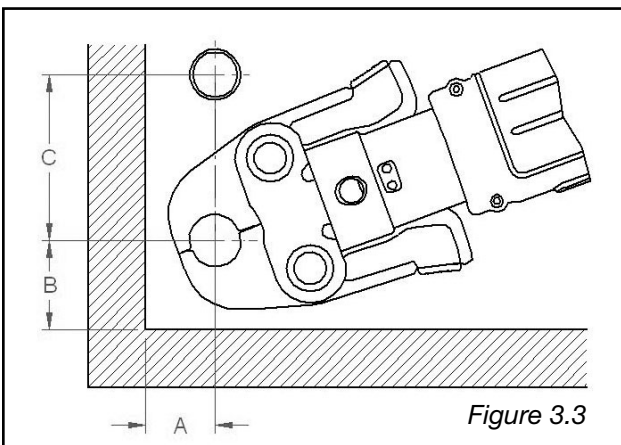

Figure 3.3

Pipe Diameter	A minimum		B minimum		C minimum	
	in	mm	in	mm	in	mm
1/2"	1-1/4	32	1-7/8	48	3	76
3/4"	1-1/2	38	2-1/8	54	3-1/2	89
1"	2	51	2-1/2	64	4	101

Table 3.4

3.4.3 Minimum Space Requirements for the Press Fitting Process in Front of and Behind Components

Ensure that the space required for Viega system pressing tools is available if press fittings will be executed immediately upstream and downstream from ceiling penetrations.

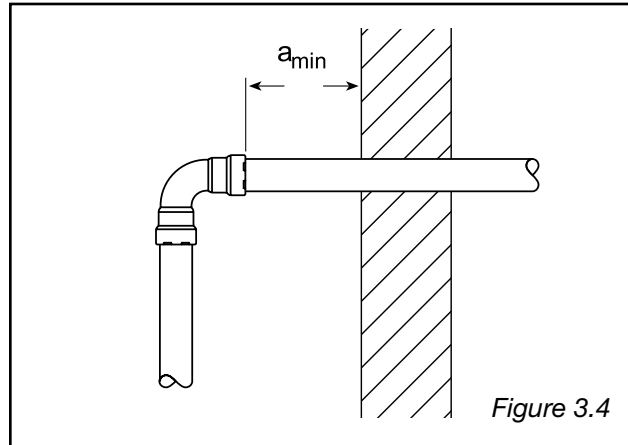
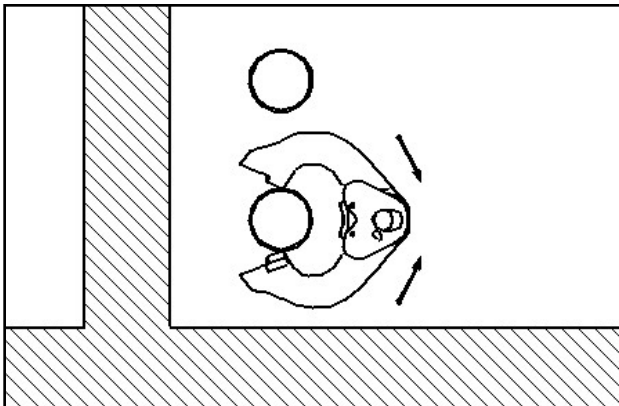

Figure 3.4

Pipe Size	Minimum space requirement, a_{min} for press tools
	RIDGID RP 330-B and 330-C Press Tool in (mm)
1/2" to 1"	1-1/2" (38)
1-1/4" to 2"	3/8" (10)

Table 3.5

3.4.4 Pressing with Ring and Actuator in Tight Quarters



1. Place the press ring around the fitting from the front...

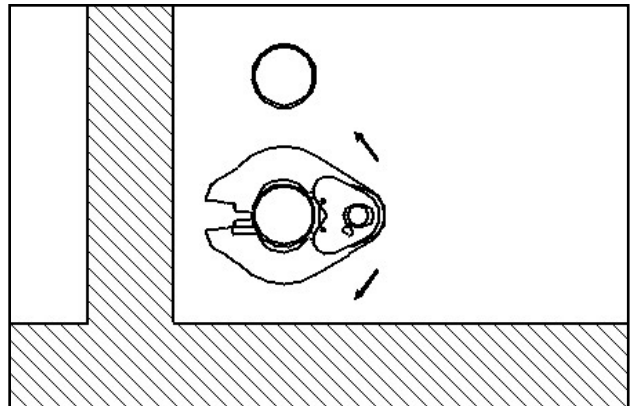

2. ...until the press ring is resting on the fitting

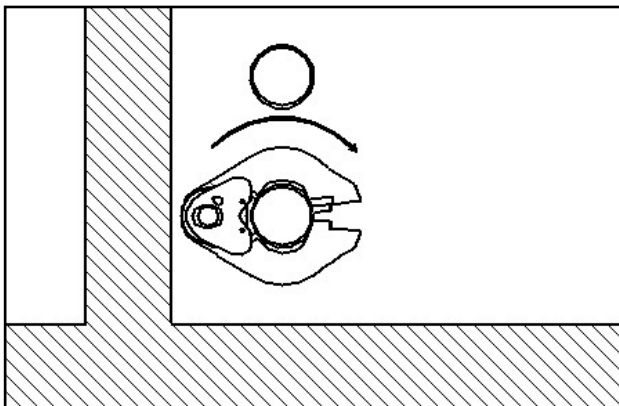

3. Keep the press ring closed and rotate about the fitting until the opening is toward the front

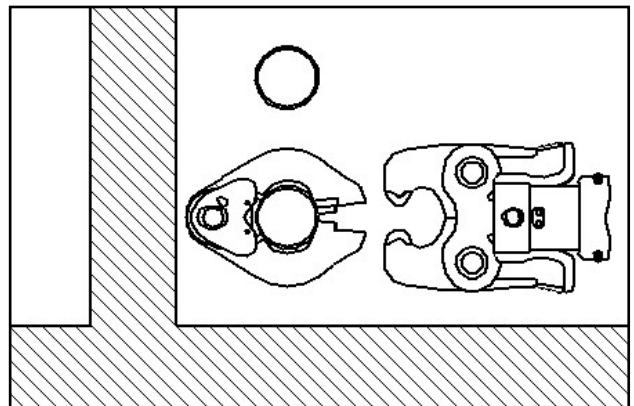

4. Insert the press ring actuator and start the press cycle

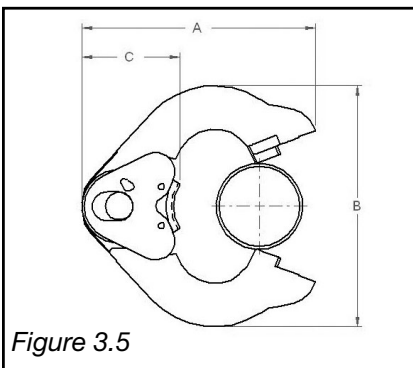

Figure 3.5

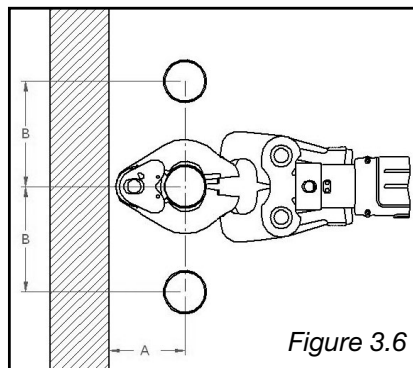

Figure 3.6

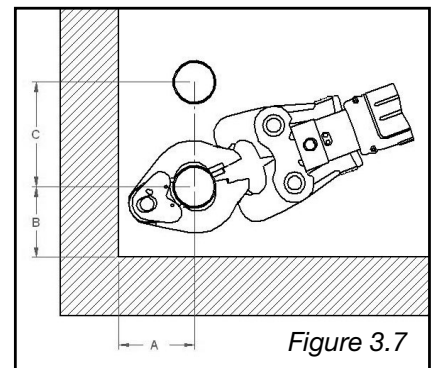

Figure 3.7

Pipe Diameter	A in (mm)	B in (mm)	C in (mm)
1-1/4"	6 (152)	6-1/4 (159)	2-1/2 (64)
1-1/2"	6 (152)	6-3/4 (171)	2-5/8 (67)
2"	6 (152)	6-7/8 (175)	2-1/2 (64)

Table 3.6

Pipe Diameter	A in (mm)	B in (mm)
1-1/4"	3-3/4 (95)	4-7/8 (124)
1-1/2"	4 (102)	5-1/8 (130)
2"	4 (102)	5-3/8 (137)

Table 3.7

Pipe Diameter	A in (mm)	B in (mm)	C in (mm)
1-1/4"	3-3/4 (95)	3-3/4 (95)	4-7/8 (124)
1-1/2"	4 (102)	4 (102)	5-1/8 (130)
2"	4 (102)	4 (102)	5-3/8 (137)

Table 3.8

3.5 Welding Requirements

The following requirements must be considered when welding in the same vicinity as Viega MegaPress and MegaPressG fittings.

3.5.1 Welding Adjacent to Viega MegaPress and MegaPressG Fittings

When welding adjacent to a Viega MegaPress or MegaPressG connection, the installer must remain 4" away from the connection to prevent damage to the sealing element. The installer should take the following precautions to keep the Viega MegaPress connection cool while welding:

- Wrapping the connection with a cold wet rag
- Protecting the connection with a weld blanket
- Fabricating weld connections prior to installing the pressed fitting, making sure the pipe has cooled before installing the fitting
- Consistently applying "spray type" spot freezing

3.5.2 Welding In Line with Viega MegaPress and MegaPressG Fittings

When welding in line with Viega MegaPress or MegaPressG fittings, the installer must remain a minimum of 3 pipe diameters away from the Viega MegaPress connection to prevent damage to the sealing element. The installer should take the following precautions to keep the Viega MegaPress connection cool while welding:

- Wrapping the connection with a cold wet rag
- Protecting the connection with a weld blanket
- Fabricating weld connections prior to installing the pressed fitting making sure the pipe has cooled before installing the fitting
- Consistently applying "spray type" spot freezing

3.6 General Installation Requirements

Viega MegaPress and MegaPressG fitting systems must be installed while considering the following general industry requirements.

3.6.1 Expansion

Thermal expansion in installed systems generate stresses in pipes and appliance connectors. Compensation must be allowed for expansion and contraction that may occur within the piping system. Expansion joints or Mechanical expansion compensators may be used to alleviate these stresses.

3.6.2 Electrical Bonding

When properly installed, Viega MegaPress and MegaPressG fittings comply with section 1211.15, Electrical Bonding and Grounding, of the Uniform Plumbing Code and section 310 of the International Fuel Gas Code.

The mechanical press provides continuous metal to metal contact between fitting and pipe. The press ensures the continuity of the bonding through this contact.

3.6.3 Piping Exposed to Freezing Temperatures

In Viega MegaPress systems, the EPDM sealing element can be installed in ambient temperatures down to 0° F. The HNBR sealing element available with Viega MegaPressG can be installed in ambient temperatures down to -40° F. Piping systems exposed to freezing temperatures must be protected per acceptable engineering practices, codes and as required by the local authority.

3.6.4 Corrosion Protection

Viega MegaPress and MegaPressG fittings exposed to corrosive action, such as soil conditions or moisture, must be protected in an approved manner in accordance with NFPA 54 section 404.8, NACE Standard RP0169-2002 section 5, 2009 UPC Chapter 6 section 609.3.1, 2009 UMC Chapter 13 section 1312.1.3 and in a manner satisfactory to the local code official.

3.6.5 Concealed Spaces

Viega MegaPressG has been examined according to the construction and performance criteria in the CSA requirement LC-4 and was found acceptable. Specific performance tests were conducted to evaluate the fittings for use in concealed locations.

3.6.6 Underground Installations

Viega MegaPress and MegaPressG fitting systems and steel pipe are approved for underground installations. However, any installations must meet all state and local codes, including those for underground.

Proper authorization must be obtained prior to underground installation.

3.6.7 Pressure Testing

The pressure testing of installed pipe is to be completed in accordance with local codes or in the absence of local codes in accordance with NFPA 54 or NFPA 58 respectively.

3.6.8 Transition Connections

The Viega MegaPress systems 1/2" – 2" can be joined with off-the-shelf threaded fittings.

In this regard:

1. The threaded connection is made first.
2. The press fitting is made second.

This process avoids unnecessary torsion.

3.6.9 Pipe Hangers

Hangers and supports must conform to the requirements of ANSI/MSS SP 58 and SP 59, pipe hangers and supports, materials, design and manufacture. Supports, hangers and anchors are to be installed in a manner that does not interfere with the free expansion and contraction of the piping. All parts of the support equipment need to be designed and installed to not disengage due to movement of the supported piping. Sliding hangers must be positioned so that they cannot unintentionally become rigid hangers when the system is in use. See Fig. 3.9. Fig. 3.10 shows a sliding piping hanger that becomes a rigid hanger with spacing in excess of 10".

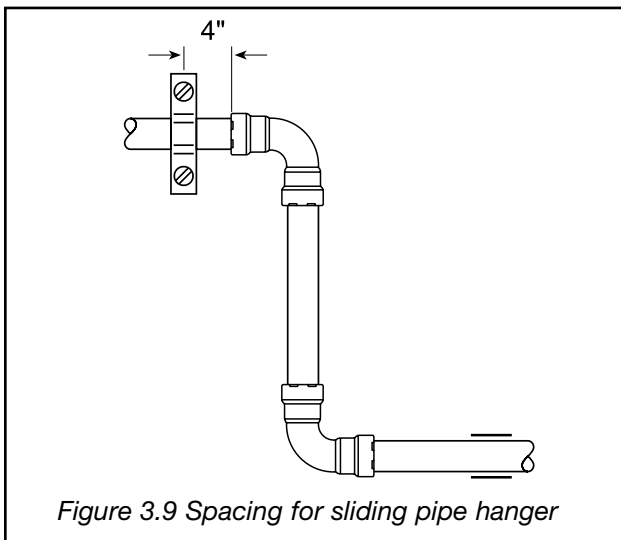

Figure 3.9 Spacing for sliding pipe hanger

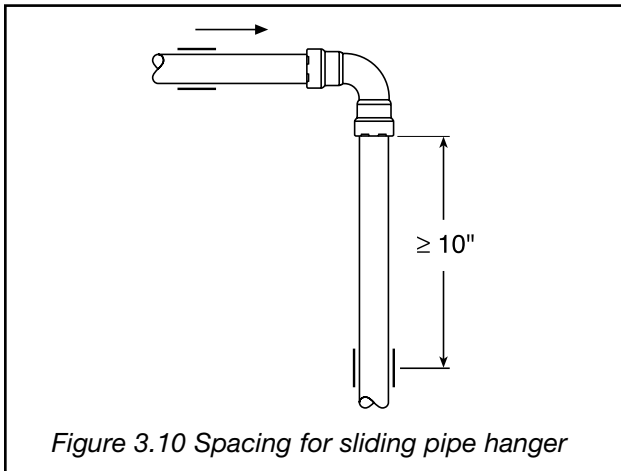

Figure 3.10 Spacing for sliding pipe hanger

Pipe Size (in)	Steel Pipe Max. Span (ft)	Min. Rod Diameter (in)
1/2 - 3/4	6	3/8
3/4 - 1	8	3/8
1-1/4 - 2	10	3/8

Table 3.9 Hanger Spacing

3.7 Viega MegaPress and MegaPressG Installation Requirements

The following are special requirements to consider when installing Viega MegaPress and MegaPressG fitting systems.

3.7.1 Rotating a Pressed Fitting

Once a Viega MegaPress or MegaPressG fitting has been pressed, it can be rotated (not by hand), but once rotated more than 5 degrees, the fitting must be re-pressed to restore the resistance to rotational movement.

3.7.2 Deflection

When pressing the Viega MegaPress and MegaPressG fittings in a system, the deformation of the fitting is constant. This allows for a consistent leak free joint every time and is a result of the pressing technique.

The pressing process can cause deflection (angular misalignment) to occur. Deflection while pressing can be corrected by alternating the position of the press tool on each fitting connection. An example would be placing the press tool on the right side of the first press connection and alternating to the left side of the press fitting on the second connection.

While deflection cannot be completely eliminated, it can be minimized using this method.

3.8 Identification

All Viega MegaPress and MegaPressG black steel piping systems must be continuously marked in accordance with ANSI A13.1 or as required by the local authority having jurisdiction.

3.9 Viega MegaPress and MegaPressG Fitting System 1/2" – 2" Installation



Read and understand all instructions for installing Viega MegaPress and MegaPressG fittings. Failure to follow all instructions may result in extensive property damage, serious injury or death.

Note: Piping shall be free of surface imperfections.

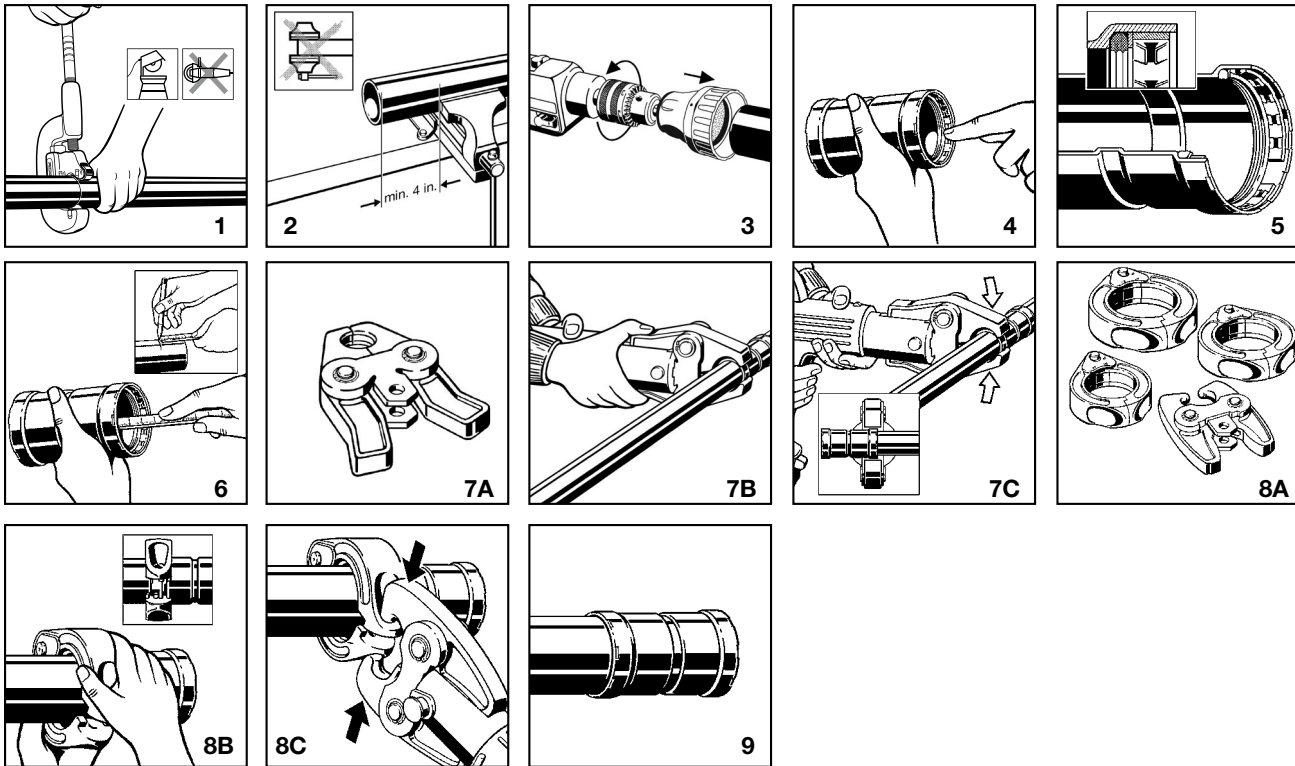

1. Cut piping at right angles using displacement type cutter.
2. Keep end of piping a minimum of 4" away from the contact area of the vise to prevent possible damage to the piping in the press area. See RIDGID Manual for minimum clearance required for prep tools.
3. Remove burr from inside and outside of piping and prep to proper insertion depth using a preparation tool or fine grit sandpaper.
4. Check seal and grip ring for correct fit. Do not use oils or lubricants.
5. Illustration demonstrates proper fit of grip ring, separation ring and sealing element.
6. Mark proper insertion depth as indicated by the Table 3.1 (pg 8). Improper insertion depth may result in an improper seal.
- 7a. Viega MegaPress 1/2" - 1" fitting connections must be performed with MegaPress Jaws. See Ridgid Operator's Manual for proper tool instructions.
- 7b. Open the MegaPress Jaw and place at right angles on the fitting. Visually check insertion depth using mark on piping.
- 7c. Start pressing process and hold the trigger until the jaw has engaged the fitting. Keep extremities and foreign objects away from MegaPress Jaw during pressing operation to prevent injury or incomplete press.
- 8a. Viega MegaPress 1-1/4" - 2" fitting connections must be performed with MegaPress Rings and V2 Actuator. See Operator's Manual for proper tool instructions.
- 8b. Open MegaPress Ring and place at right angles on the fitting. MegaPress Ring must be engaged on the fitting bead. Check insertion depth.
- 8c. Place V2 Actuator onto MegaPress Ring and start pressing process. Hold the trigger until the Actuator has engaged the MegaPress Ring. Keep extremities and foreign objects away from MegaPress Ring and V2 Actuator during pressing operation to prevent injury or incomplete press.
9. Remove MegaPress Jaw from fitting or release V2 Actuator from RIDGID MegaPress Ring and then remove MegaPress Ring from the fitting on completion of press. Remove control label to indicate press has been completed

MEGAPRESS® VIEGA LIMITED WARRANTY

Subject to the conditions and limitations in this Limited Warranty, Viega LLC (Viega) warrants to end users, installers, and distribution houses that its Viega MEGAPRESS metal press fittings (Viega Product) with application appropriate sealing element when properly installed shall be free from failure caused by manufacturing defects for a period of ten (10) years from date of installation in Viega MEGAPRESS Approved Applications for fluids/water, oil and lubricant, and gases under Viega specified system operating conditions.

Under this Limited Warranty, you only have a right to a remedy if the failure or leak resulted from a manufacturing defect in the Viega Product and the failure or leak occurs during the warranty period. You do not have a remedy under this warranty and the warranty remedy does not apply if the failure or any resulting damage is caused by (1) components other than those manufactured or sold by Viega, such as black iron pipe; (2) not designing, installing, inspecting, testing, or maintaining the Viega Product in accordance with Viega's installation and product instructions in effect at the time of installation and other specifications and approvals applicable to the installation; (3) use of Viega Product under non recommended system operating conditions, improper handling and protection of the Viega Product prior to, during and after installation, inadequate freeze protection, or exposure to environmental conditions not recommended for the application; or (4) acts of nature, such as, but not limited to, earthquakes, fire, or weather damage. In the event of a leak or other failure of the Viega Product covered by this warranty, it is the responsibility of the end user to take appropriate measures to mitigate any damage, to include making timely repairs. Only if the warranty applies will Viega be responsible for the remedy under this warranty. The part or parts which you claim failed should be kept and Viega contacted by writing to the address below or telephoning 1-877-843-4362 within thirty (30) calendar days after the leak or other failure and identifying yourself as having a warranty claim. You should be prepared to ship, at your expense, the product which you claim failed due to a manufacturing defect, document the date of installation, and the amount of the repair or replacement if performed by you. Within a reasonable time after receiving the product, Viega will investigate the reasons for the failure, which includes the right to inspect the product at a Viega location and reasonable access to the site of damage. Viega will notify you in writing as to the results of its review.

In the event that Viega determines that the failure or leak was the result of a manufacturing defect in the Viega Product covered by this warranty and this warranty applies, the **EXCLUSIVE AND ONLY REMEDY** under this warranty shall be the reimbursement for reasonable charges for repair or replacement of the Viega Product itself. **VIEGA SHALL NOT BE LIABLE FOR ANY CONSEQUENTIAL OR OTHER DAMAGE (FOR EXAMPLE, ECONOMIC LOSS, WATER OR PROPERTY OR MOLD REMEDIATION) UNDER ANY LEGAL THEORY AND WHETHER ASSERTED BY DIRECT ACTION, FOR CONTRIBUTION OR INDEMNITY OR OTHERWISE.**

THE ABOVE WARRANTY IS IN LIEU OF ALL OTHER WARRANTIES, EXPRESS OR IMPLIED, INCLUDING, BUT NOT LIMITED TO, THE IMPLIED WARRANTIES OF MERCHANTABILITY AND FITNESS FOR A PARTICULAR PURPOSE OR ANY STATUTE OF LIMITATIONS RELATING TO SUCH WARRANTIES. Other than this Limited Warranty, Viega does not authorize any person or firm to create for it any other obligation or liability in connection with its products.

This Limited Warranty gives you specific legal rights and you also may have other rights which may vary from state to state. This warranty shall be interpreted and applied under the law of the state in which the product is installed and is intended as a **COMMERCIAL WARRANTY**.

MEGAPRESS WARRANTY, 9/2011

The logo consists of the word "viega" in a white, lowercase, sans-serif font, centered within a solid black rectangular box.

**Viega... The global
leader in plumbing,
heating and pipe
joining systems**

©2011, ProPress®, FostaPEX®, Seapress®, MegaPress®, MegaPressG® and Viega® are registered trademarks of Viega GmbH & Co. PureFlow®, Smart Connect®, Climate Panel®, Climate Mat®, Climate Trak®, MANABLOC®, Radiant Wizard®, S-no-Ice®, Snap Panel®, XL® and XL-C® are registered trademarks of Viega LLC. MiniBloc™, ProRadiant™, PolyAlloy™, SmartLoop™ and Zero Lead™ are trademarks of Viega LLC; GeoFusion™, ProPressG™ and ViegaPEX™ are trademarks of Viega GmbH & Co. KG.

301 N. Main, 9th Floor, Wichita, KS 67202 Phone: 1-800-976-9819 Fax: 1-316-426-7618 www.viega.com

IM-MegaPress 1011

Viega MegaPress® Warranty



MEGAPRESS® VIEGA LIMITED WARRANTY

Subject to the conditions and limitations in this Limited Warranty, Viega LLC (Viega) warrants to end users, installers, and distribution houses that its Viega MEGAPRESS metal press fittings (Viega Product) with application appropriate sealing element when properly installed shall be free from failure caused by manufacturing defects for a period of ten (10) years from date of installation in Viega MEGAPRESS Approved Applications for fluids/water, oil and lubricant, and gases under Viega specified system operating conditions.

Under this Limited Warranty, you only have a right to a remedy if the failure or leak resulted from a manufacturing defect in the Viega Product and the failure or leak occurs during the warranty period. You do not have a remedy under this warranty and the warranty remedy does not apply if the failure or any resulting damage is caused by (1) components other than those manufactured or sold by Viega, such as black iron pipe; (2) not designing, installing, inspecting, testing, or maintaining the Viega Product in accordance with Viega's installation and product instructions in effect at the time of installation and other specifications and approvals applicable to the installation; (3) use of Viega Product under non recommended system operating conditions, improper handling and protection of the Viega Product prior to, during and after installation, inadequate freeze protection, or exposure to environmental conditions not recommended for the application; or (4) acts of nature, such as, but not limited to, earthquakes, fire, or weather damage. In the event of a leak or other failure of the Viega Product covered by this warranty, it is the responsibility of the end user to take appropriate measures to mitigate any damage, to include making timely repairs. Only if the warranty applies will Viega be responsible for the remedy under this warranty. The part or parts which you claim failed should be kept and Viega contacted by writing to the address below or telephoning 1-877-843-4362 within thirty (30) calendar days after the leak or other failure and identifying yourself as having a warranty claim. You should be prepared to ship, at your expense, the product which you claim failed due to a manufacturing defect, document the date of installation, and the amount of the repair or replacement if performed by you. Within a reasonable time after receiving the product, Viega will investigate the reasons for the failure, which includes the right to inspect the product at a Viega location and reasonable access to the site of damage. Viega will notify you in writing as to the results of its review.

In the event that Viega determines that the failure or leak was the result of a manufacturing defect in the Viega Product covered by this warranty and this warranty applies, the EXCLUSIVE AND ONLY REMEDY under this warranty shall be the reimbursement for reasonable charges for repair or replacement of the Viega Product itself. VIEGA SHALL NOT BE LIABLE FOR ANY CONSEQUENTIAL OR OTHER DAMAGE (FOR EXAMPLE, ECONOMIC LOSS, WATER OR PROPERTY OR MOLD REMEDIATION) UNDER ANY LEGAL THEORY AND WHETHER ASSERTED BY DIRECT ACTION, FOR CONTRIBUTION OR INDEMNITY OR OTHERWISE.

THE ABOVE WARRANTY IS IN LIEU OF ALL OTHER WARRANTIES, EXPRESS OR IMPLIED, INCLUDING, BUT NOT LIMITED TO, THE IMPLIED WARRANTIES OF MERCHANTABILITY AND FITNESS FOR A PARTICULAR PURPOSE OR ANY STATUTE OF LIMITATIONS RELATING TO SUCH WARRANTIES. Other than this Limited Warranty, Viega does not authorize any person or firm to create for it any other obligation or liability in connection with its products.

This Limited Warranty gives you specific legal rights and you also may have other rights which may vary from state to state. This warranty shall be interpreted and applied under the law of the state in which the product is installed and is intended as a COMMERCIAL WARRANTY.

MEGAPRESS WARRANTY, 9/2011