

Water Supply Angle Stop Valve

Product Specifications

FEATURES

- Easy Quarter Turn Operation
- Inlet - 1/2" FIP
- Outlet - 3/8" O.D. Comp.
- Temperature: 40° to 140° Fahrenheit
- Pressure: 125 PSI Maximum
- Material: Machined One Piece Brass Body
- Chrome Plated



MLQTR17CX

APPLICABLE STANDARDS/CODES

Specified model meets or exceeds the following:

- ASME A112.18.1/CSA B125.1
- IAPMO/cUPC
- NSF/ANSI 372
- NSF/ANSI 61 – Sec. 9
- *≤ .25% Pb
- Inlet Pipe Threads Comply with ANSI B1.20.1

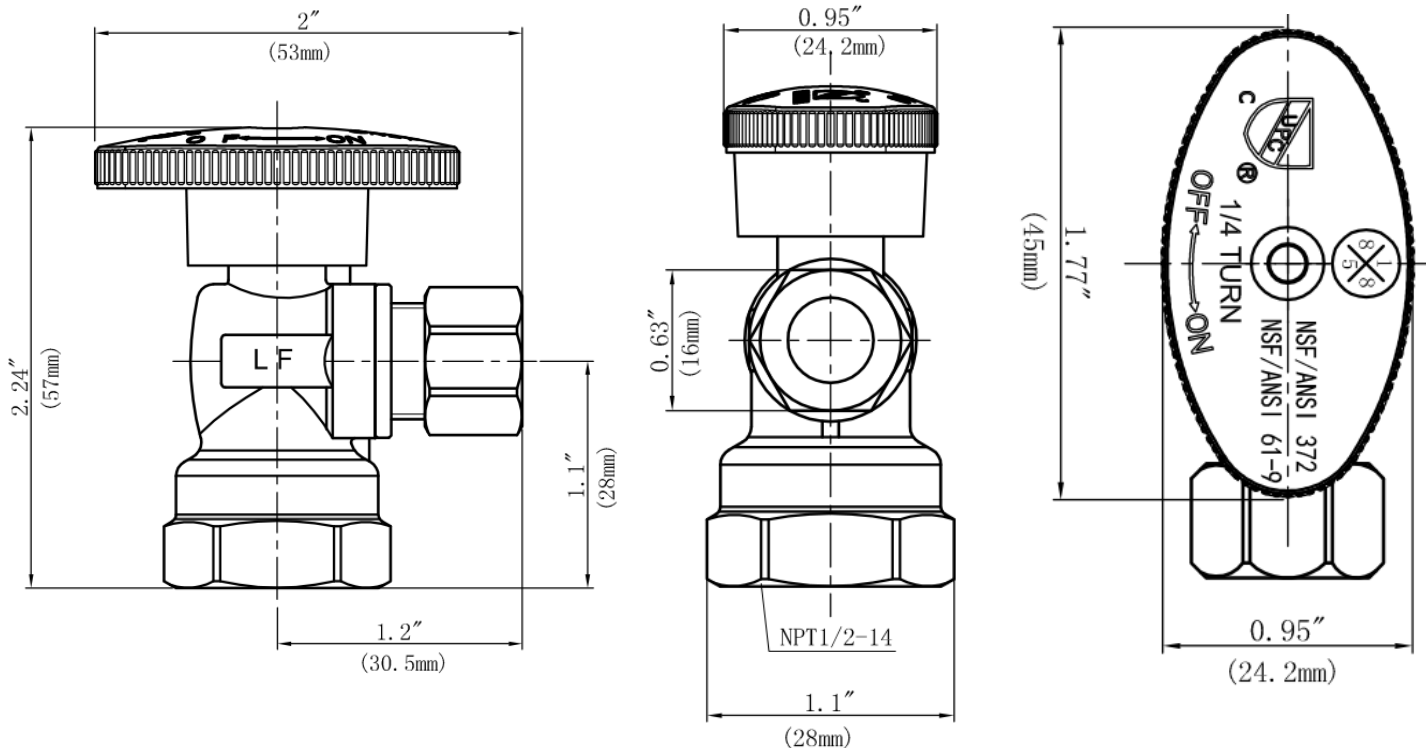

Warranty

See warranty information for more details.

All dimensions listed are nominal. MAINLINE® reserves the right to make product and material changes at any time without notice.

NSF/ANSI 372
NSF/ANSI 61-9



Contact your sales representative for more information or visit our website at mainlinecollection.com