

MEDICINE CABINET BOTIQUÍN

Models:

LXMCURB3026-BN

LXMCURB3026-BM

MMC3026-BN | MMC3026-BL

COPY THE MODEL NUMBER FOR YOUR RECORDS HERE #
COPIE EL NÚMERO DE MODELO PARA SUS REGISTROS AQUÍ #







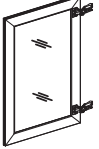
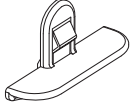

READ THE INSTRUCTIONS CAREFULLY

Familiarize yourself with all the parts as shown in the exploded view. The exploded view will also provide a helpful reference when relating to the location of the various parts and how they are mounted.

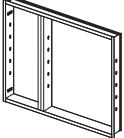

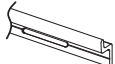
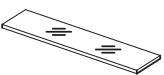

LEA LAS INSTRUCCIONES DETENIDAMENTE

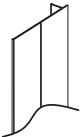
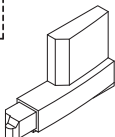
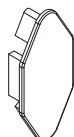
Familiarícese con todas las piezas como se muestra en la vista ampliada. La vista ampliada también proporcionará una referencia útil cuando se relacione con la ubicación de las diversas piezas y cómo se montan.

PARTS LIST / LISTA DE PARTES
INCLUDED / INCLUIDO

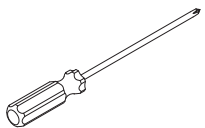
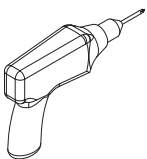
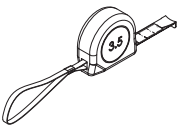
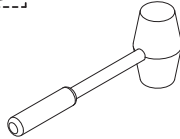
				
DOOR (2 pcs)	CLEAR SHELF CLIP (8 pcs)	HOLE PLUG (4 pcs)	CABINET (1 pcs)	SCREW #10-1 1/2 (5 pcs)
				
TOP Z-CLIP (2 pcs)	WALL PLUG (5 pcs)	MOUNTING BRACKET (1 pcs)	GLASS SHELF (4 pcs)	SCREW HEAD COVER CAP (4 pcs)
				
COVER PLATE (2 pcs)	BUMPER (4 pcs)	DECORATIVE COVER (12 pcs)		

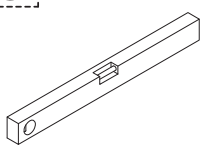
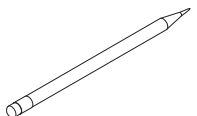
TOOLS REQUIRED / HERRAMIENTAS REQUERIDAS
NOT INCLUDED / NO INCLUIDO

				 5/16"
SCREW DRIVERS	DRILL	MEASURE TAPE	RUBBER Mallet	DRILL BITS
				
LEVEL	PENCIL	SAFETY GLASSES		

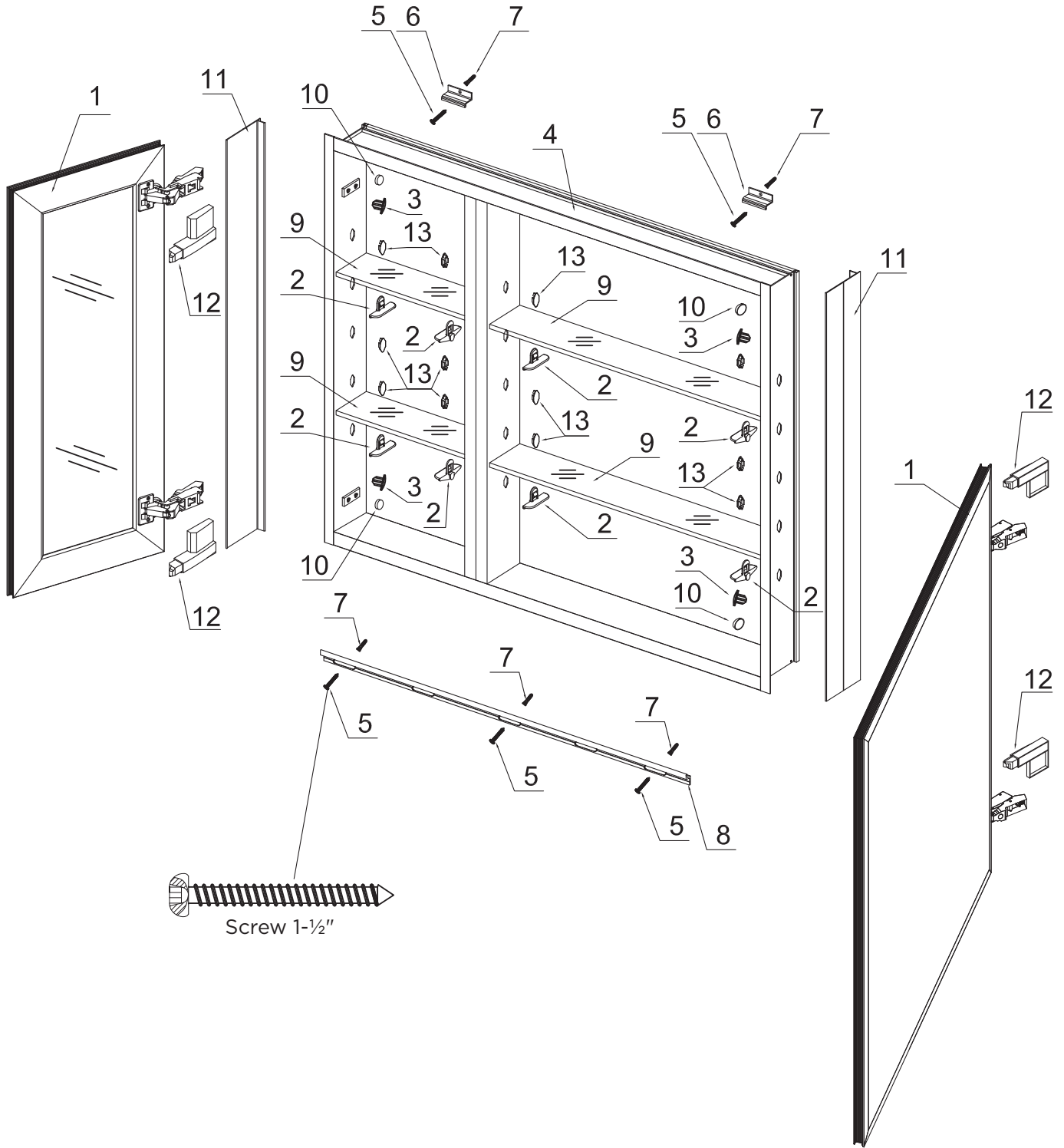

Screw 1-1/2"



1 Determining Measurement and Direction:

Model No.	Height	Width	Depth	Tolerance
3026	25"	29-1/2"	4"	± 1/8"

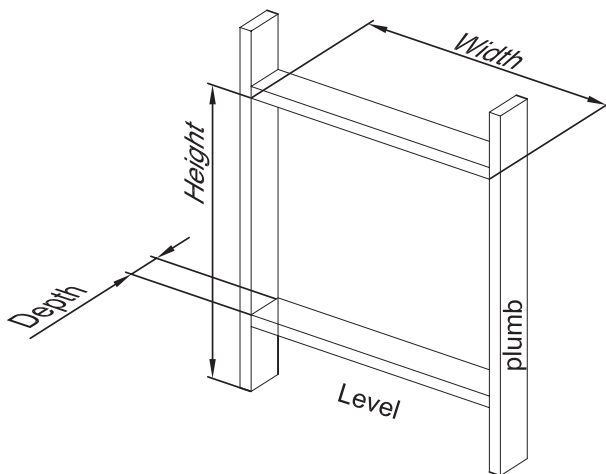
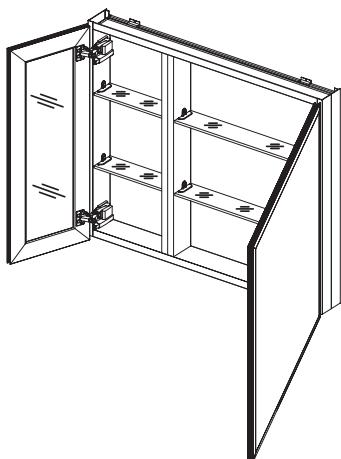

Fig 1

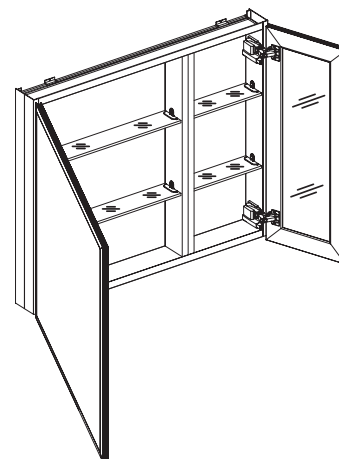

Fig 2

2 If needed ,please turn over the upside to downside ,you may get the opposite hand installations .



Left hand Installation



Right hand Installation



3 Recessed or semi-recessed

1. Peel off the side kits from the cabinet as figure shown.

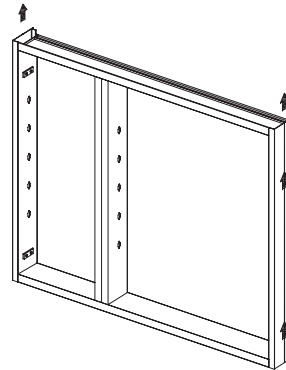

Peel off the side kits

2. Make sure hinges are on correct side of opening for left hand or right hand operation. Place cabinet box into rough opening. On fully recessed applications, make sure cabinet flange covers rough opening evenly all around (Fig 3). On semi-recess applications, mirror edges should meet wall surface. (Fig 4). Shim as needed.

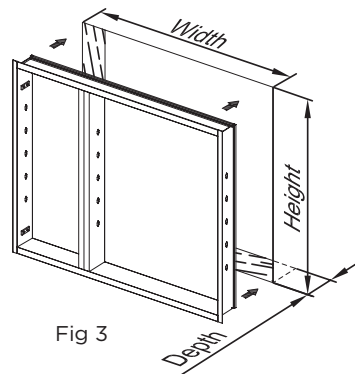

Fig 3

Semi-recessed

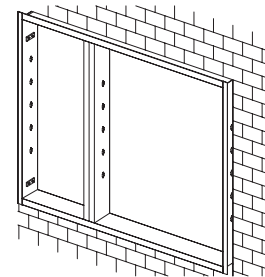

Fig 4

3. Insert four (4) #10 x 1 1/2" screws (5) into four locations provided for recessed installation (Fig 5). Be careful not to overtighten. Make sure cabinet is centered in rough opening. Cover screws with provided caps (10).

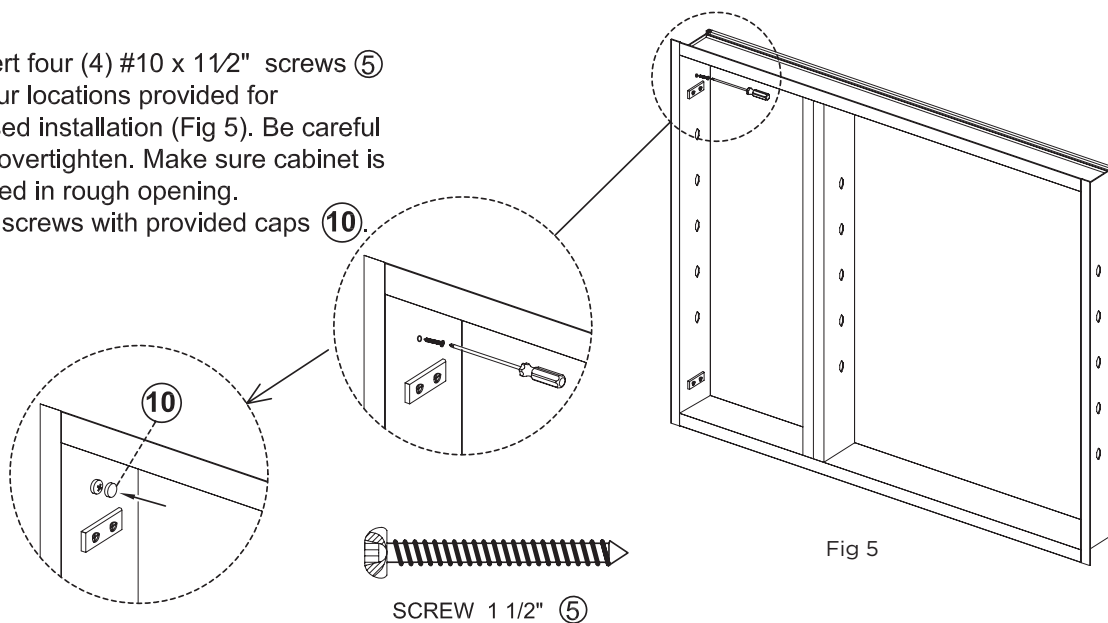

Fig 5

SCREW 1 1/2" (5)



4 How to Surface Mount Cabinet

If installing in combination with a middle mirror/shelf kit, please see "Center Mirror/Shelf Kit Installation" Directions that came with your center mirror prior to performing the steps below

1. Establish precise height and draw a level horizontal line (Fig 6).
IMPORTANT: Detect medicine cabinet at precise height. Make sure there is at least 1" of clearance above any obstructions.

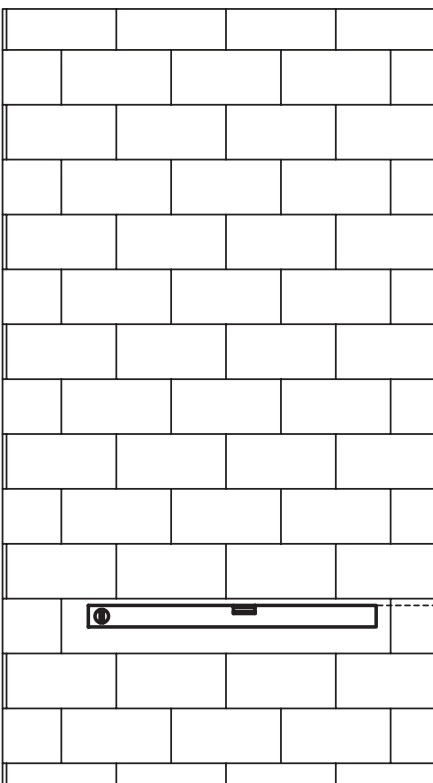
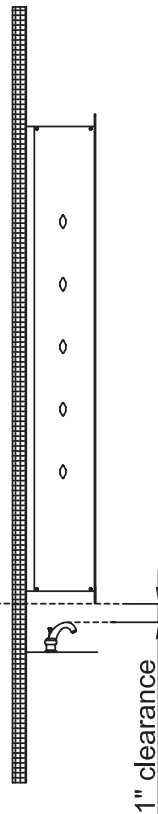

Fig 6



1" clearance

2. Place bottom of wall bracket on horizontal line and at correct position left to right and mark holes on wall (Fig 7).

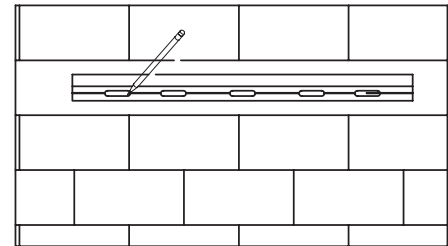

Fig 7

3. Drill 8 mm hole if required for wall anchor and place wall anchor in hole. Mount wall bracket with #10 x 1 1/2" ⑤ screws. (Fig 8)



SCREW 1 1/2" ⑤

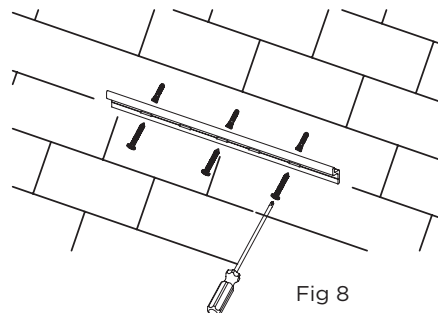

Fig 8



4. Insert surface mount z-clips ⑥ as shown (Fig 9 & 10).

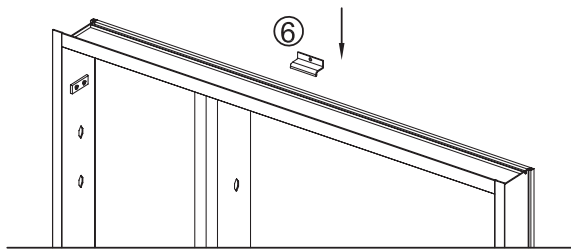

Fig 9

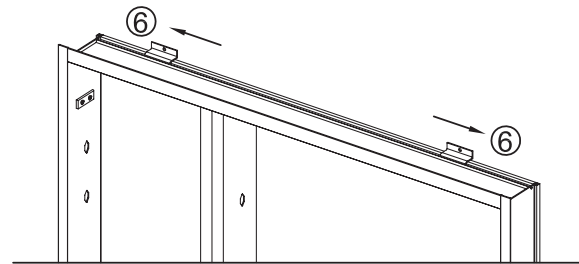

Fig 10

5. Place cabinet into wall bracket (Fig 11). Mark hole locations of z-clips (Fig 12). When determining location, it is recommended that at least one z-clip be located at a stud . Detach cabinet and drill 8mm hole if needed for anchor, and place in anchor in hole.

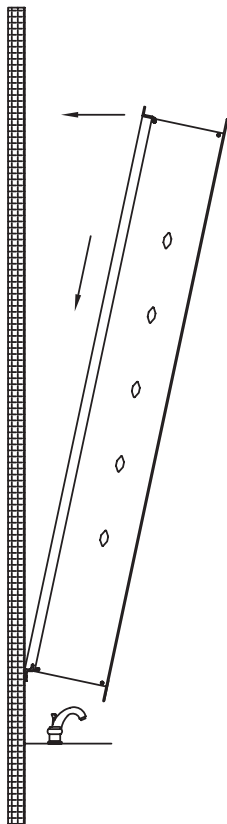

Fig 11

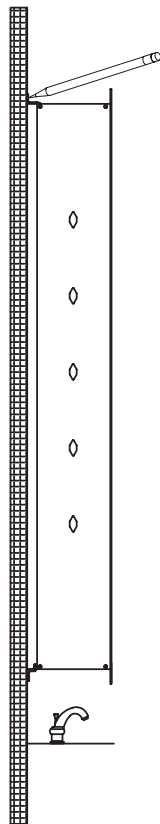

Fig 12

6 .Remount cabinet and connect with #10 x 1 1/2" ⑤ screws (Fig 13). Be careful not to damage or scrape the top flange

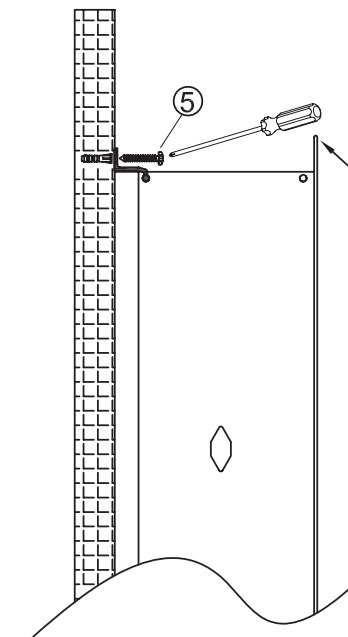
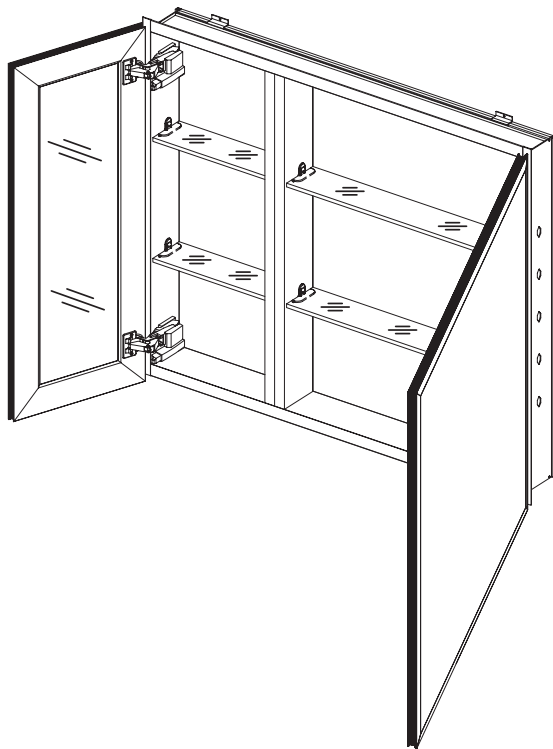

Fig 13

NOTE:
Be careful not
to damage or
scratch the top
flange

5 Door Installation

1. Remove protective packaging from door, be careful not to bump edges of mirror. Line hinges up against hinge mounting plates. Snap into position (Fig 14).



Mounting Plate

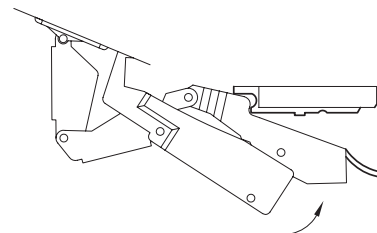
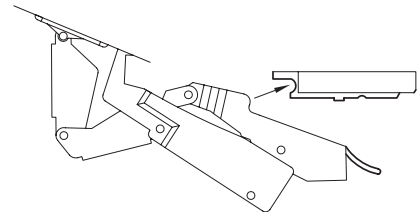

Snap into position

Fig 14

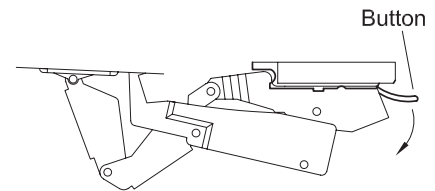

Button

Pull to release

2. Door should "snap" locked when about 1" from being fully closed. Door should be placed even in relation to cabinet. Insert bumper 12 (Fig 15).

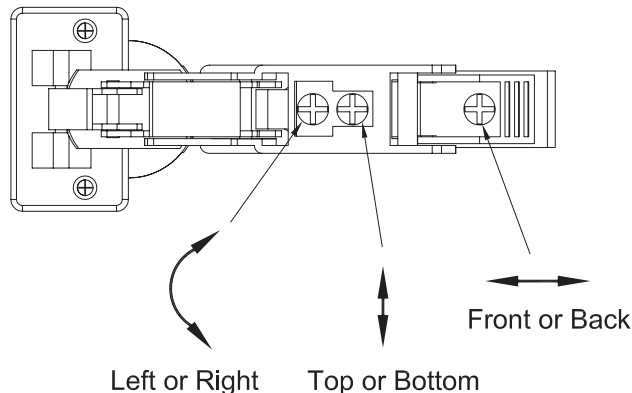
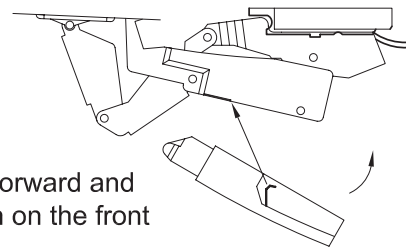
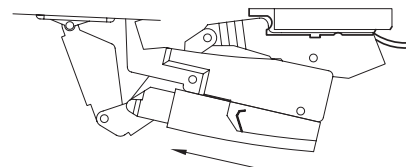

Fig 15



Pull forward and down on the front

Push down on the back



Pull forward and up simultaneously



6 Additional Item Installation

1. Insert clear shelf clip ② into appropriate hole location using 2 clips per shelf (Fig 16).

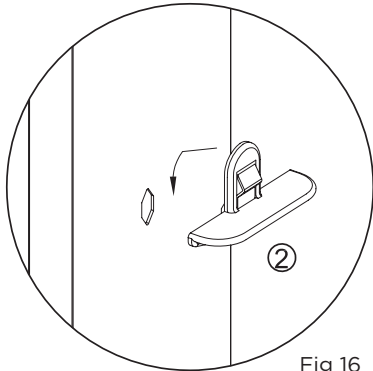
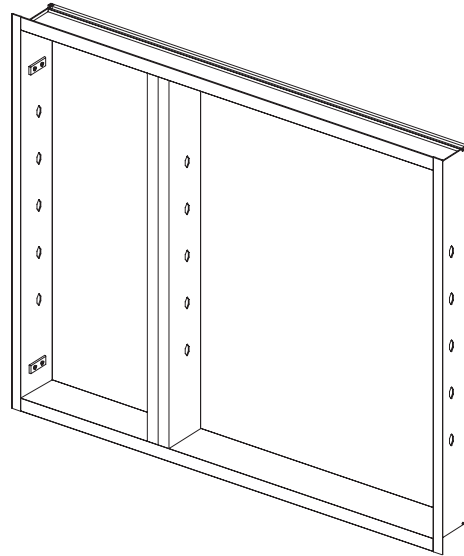

Fig 16



2. Place glass shelf ⑨ on top of clear shelf clips making sure shelf is against back of cabinet. Press lightly to adhere the shelf clip sticker (Fig 17).

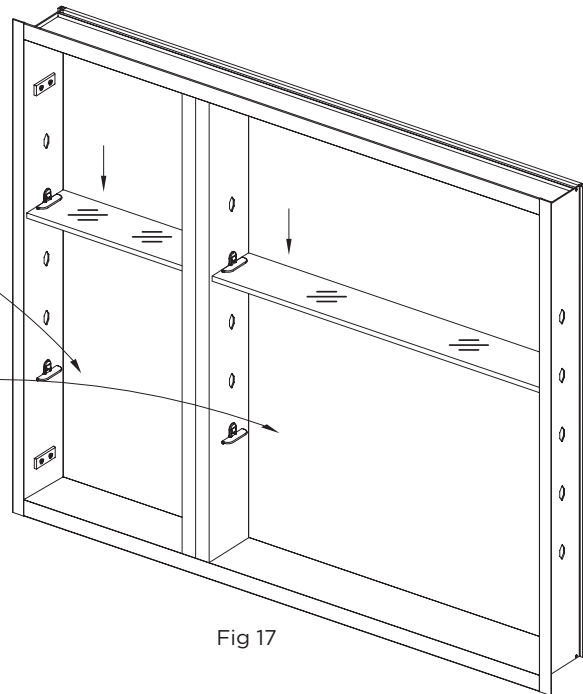
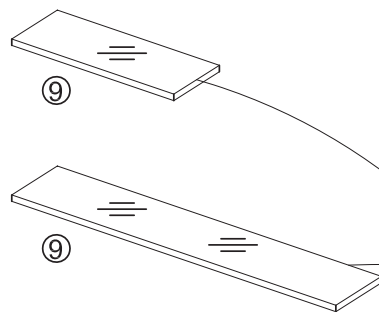

Fig 17

3. Fill remaining holes with hole plugs ③ (Fig 18). Fill the rest of shelf clip holes with decorative covers ⑬ (Fig 19).

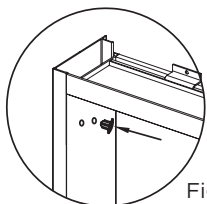

Fig 18

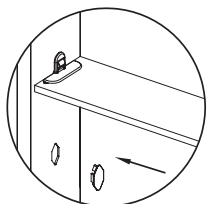
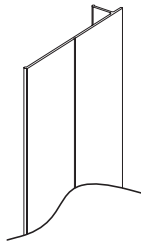
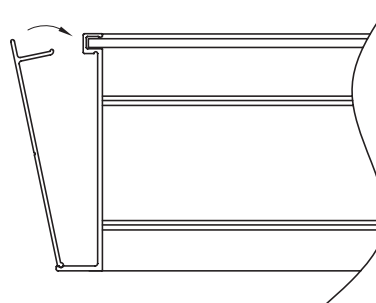
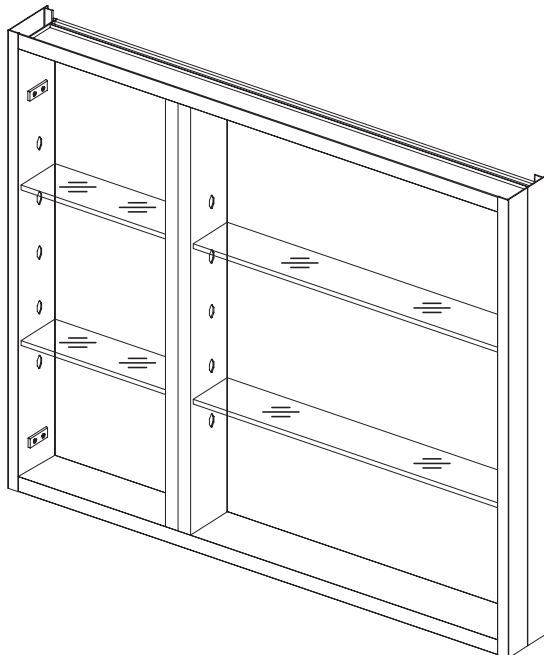
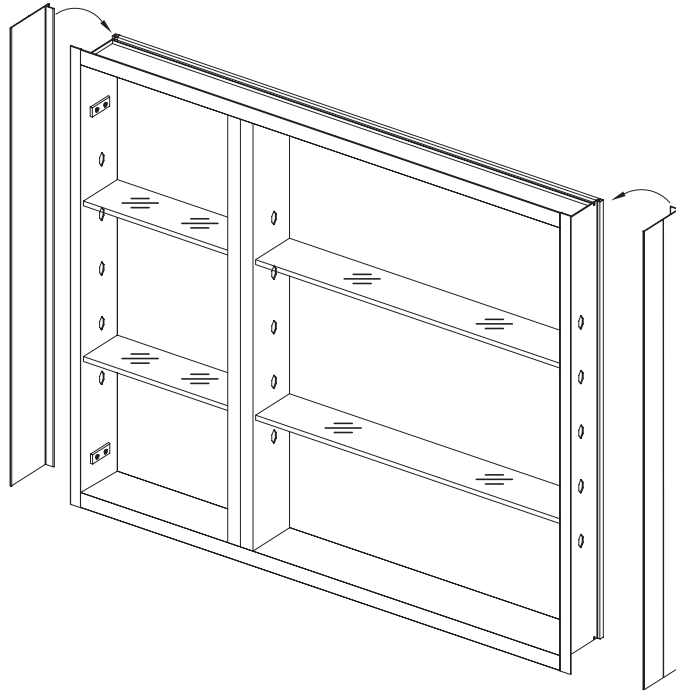

Fig 19

7 Install cover plate



COVER PLATE (2 pcs)



HOW TO KEEP YOUR FURNITURE LOOKING BEAUTIFUL

Quality wood furniture is a significant investment expected to last for generations. To maintain its beauty and help it last, wood furniture needs the right care. Your new Luxart® Andressa® furniture is finished with two to three coats of lacquer for extra depth and long-lasting durability. The sheen, or gloss, of the finish ranges from high to low, depending on the piece or collection. The finish protects the wood and adds to its beauty. No finish is totally indestructible, but with regular care, the finish will last much longer, providing years of enjoyment to you.

To protect and care for your furniture, we suggest the following:

- Avoid placing your Luxart® Andressa® furniture in direct sunlight, as sunlight causes fading.
- Clean up spills immediately. Use a blotting rather than a wiping action. Water left over a long period of time will cause white spots in the finish. Alcohol, perfume, after-shave and medications can cause severe finish damage.

CLEANING AND POLISHING YOUR FURNITURE

We recommend dusting frequently with a clean, soft, dry, lint-free cloth. Clean the surface by rubbing in the direction of the grain. We recommend polishing your furniture approximately every six months, using a clean, soft, lint-free cloth and rubbing the polish in the direction of the grain.

WHAT FURNITURE CARE PRODUCTS DO WE RECOMMEND?

We recommend polishes which contain detergents, emulsifiers and mineral oil. The detergents clean dirt from the furniture, the emulsifiers give it body to clean and last longer and the mineral oil is left behind as a barrier for dirt and moisture that could harm finishes. There's no grit to harm the finish, no wax to build up and no silicone to raise the sheen and act as a barrier for touch-up and refinishing.

SINK CARE AND MAINTENANCE

Clean the surfaces with mild soap and warm water. Then dry with a soft cloth. Clean up spills immediately. Do not use products that contain lemon, vinegar or other acids. Using this type of cleaning process will cause the finish to dull.

CLEANING GLASS MIRRORS

Ammonia or vinegar based cleaners can damage mirrors. We recommend a solution of 50% water and 50% isopropyl alcohol for mirror cleaning.

CÓMO CONSERVAR LA BELLEZA DE SUS MUEBLES

Los muebles finos de madera pueden ser una inversión considerable, que se espera que sirvan por generaciones. Para conservar su belleza y ayudar a que los muebles de madera duren mucho tiempo, es necesario darles el cuidado adecuado. Los muebles Luxart® Andressa® son acabados con dos o tres capas de laca para lograr una mejor profundidad y durabilidad. El brillo, o lustre, del acabado varía desde alto hasta bajo, lo que depende del mueble o de la colección. El acabado protege la madera y realza su belleza. Ningún acabado es completamente indestructible, pero cuidándolo regularmente, puede durar un tiempo mucho mayor, y ofrecerle muchos años de satisfacción.

Para proteger y conservar sus muebles, le ofrecemos las siguientes sugerencias:

- Evite colocar sus muebles Luxart® Andressa® bajo la luz solar directa, ya que ésta provoca su descoloración.
- Limpie inmediatamente los derrames. Séquelos absorbiendo con un paño, en lugar de frotar. El agua que se queda por mucho tiempo deja manchas blanquecinas en el acabado. El alcohol, los perfumes, las lociones para después de afeitar y los medicamentos pueden causar mucho daño al acabado.

CÓMO LIMPIAR Y LUSTRAR SUS MUEBLES

Recomendamos limpiar el polvo con frecuencia con un paño limpio, seco, suave y sin pelusas. Limpie la superficie frotando en la dirección de la veta de la madera. Recomendamos lustrar sus muebles cada seis meses aproximadamente, con paño limpio, seco, suave y sin pelusas, frotándolos en la dirección de la veta de la madera.

¿QUÉ PRODUCTOS PARA LA CONSERVACIÓN DE MUEBLES RECOMENDAMOS?

Recomendamos productos para lustrar muebles que contengan detergentes, emulsificantes y aceite mineral. Los detergentes limpian la suciedad de los muebles, los emulsificantes le dan cuerpo para que limpie y dure un mayor tiempo, y el aceite mineral deja una capa de protección contra la suciedad y la humedad que pudieran dañar el acabado. No contienen partículas abrasivas que dañen el acabado, cera que se acumule ni silicona que aumente el brillo, y actúan como una barrera para los retoques y la restauración del acabado.

CUIDADO Y MANTENIMIENTO DEL LAVAMOS

Limpie las superficies con jabón suave y agua tibia. Luego séquelas con un paño suave. Limpie inmediatamente los derrames. No use productos que contengan limón, vinagre u otros ácidos. El usar este tipo de limpiadores hará que el acabado pierda su brillo.

LIMPIEZA DE ESPEJOS DE CRISTAL

Los limpiadores a base de amoníaco o vinagre pueden dañar los espejos. Se recomienda una solución de 50% de agua y 50% de alcohol isopropílico para limpiar los espejos.

ATTENTION CONSUMER:

IMPORTANT WARRANTY INFORMATION

PLEASE DO NOT DISCARD

Thank you for your purchase.

In order to be eligible for product warranty, please register your door on our website within two (2) weeks of installation.

Go to:

<https://www.luxartcollection.com/pages/register-warranty>

Or scan the QR Code below and follow the instructions.

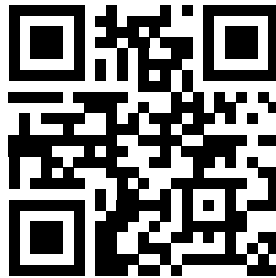

For any questions or comments about your purchase,
please contact our Customer Service at:
customerservice@luxartcollection.com

ATENCIÓN CONSUMIDOR:

INFORMACIÓN IMPORTANTE SOBRE LA GARANTÍA

POR FAVOR, NO DESCARTAR

Gracias por su compra.

Para poder beneficiarse de la garantía del producto, registre su puerta en nuestra pagina del web en un plazo de dos (2) semanas tras la instalación.

Vaya a:

<https://www.luxartcollection.com/pages/register-warranty>

O escanee el código QR que aparece a continuación
y siga las instrucciones.Or scan the QR Code below and follow the instructions.

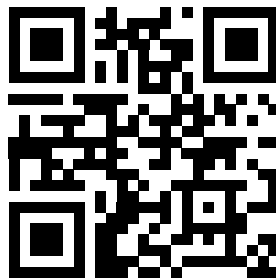

Para cualquier pregunta o comentario sobre su compra
póngase en contacto con nuestro Servicio de Atención al Cliente en:
customerservice@luxartcollection.com

LIMITED WARRANTY

Luxart® Andressa® products are covered with a 1 year limited warranty, which is as follows:

We warrant our products to be free from defects in material or workmanship for a period of 1 year from the date of delivery.

These warranties are made to the original purchaser and are limited to the repair or exchange of any parts which prove defective under normal use during the warranty period.

These warranties do not apply where products have been improperly stored or improperly installed, misused, abused, or modified in any way. They do not cover the costs of removing warranted material or the installation of replacement material.

These warranties are the sole warranties of Luxart®, and in lieu of all other warranties, express or implied, including any implied warranties of merchantability and fitness for a particular use. Labor charges for removal of or installation of warranted material as well as incidental or consequential damages are excluded. We do not assume for us any other liability in connection with the sale of our product.

GARANTÍA LIMITADA

Los productos Luxart® Andressa® están cubiertos por la garantía limitada de 1 año, que es la siguiente:

Garantizamos, por un período de 1 año contado a partir de la fecha de entrega, que nuestros productos no tienen defectos de materiales ni de mano de obra.

Estas garantías se otorgan al comprador original y quedan limitadas a la reparación o al cambio de cualquier pieza que se demuestre que se encuentra defectuosa en condiciones normales de uso, durante el período de la vigencia de la misma.

Estas garantías no amparan los casos de productos incorrectamente guardados o armados, ni el maltrato, abuso o las alteraciones de cualquier tipo. Las garantías no cubren los costos de remoción de piezas amparadas ni la instalación de piezas cambiadas.

Estas son las únicas garantías que otorga Luxart®, y se otorgan en lugar de toda otra garantía, sea expresa o implícita, incluyendo las garantías implícitas sobre la idoneidad del producto para su comercialización o para un uso determinado. Quedan excluidos los gastos de mano de obra de remoción o de instalación de las piezas amparadas, así como los daños y perjuicios accesorios o indirectos. No asumimos ninguna otra responsabilidad en relación con la venta de este producto.