



MAINLINE®

TOILET FLUSH VALVE

Product Specifications

FEATURES

- 2" flush valve
- Includes 2" float and flapper
- Plastic nut and washer included
- Fits most 2" tanks

APPLICABLE STANDARDS/CODES

*This product is in compliance with the following standard(s)

- ASME A112.19.5-2017
- CSA B45.15-17



MLTRP500

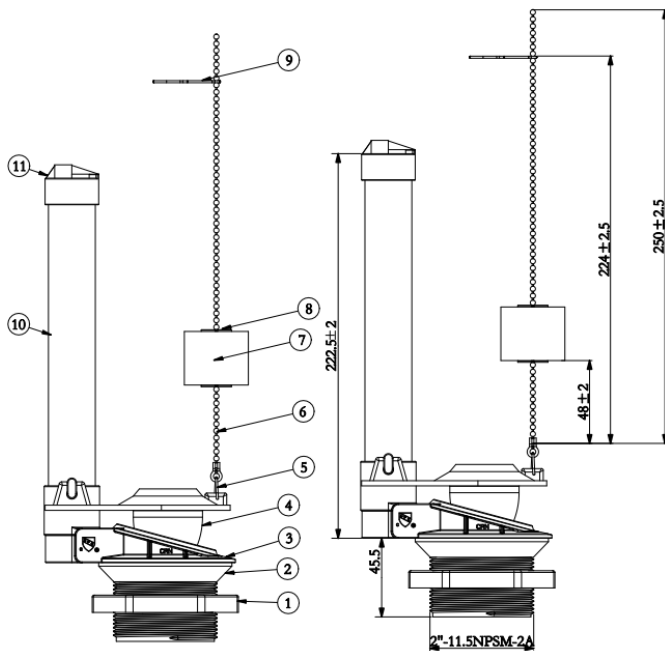

No.	Name
1	Nut
2	Seal
3	Flush Body
4	Flapper
5	Hook
6	Chain
7	Float
8	Clip
9	Hook
10	Overflow tube
11	Cap

Warranty

See warranty information for more details.

All dimensions listed are nominal. MAINLINE® reserves the right to make product and material changes at any time without notice.



Contact your sales representative for more information or visit our website at mainlinecollection.com