

LIMITED WARRANTY - BATTERY BACKUP PUMPS:

Manufacturer warrants the products specified in this warranty to be free from defects in material or workmanship for five (5) years from date of purchase. During the time period and subject to the terms and conditions, the manufacturer will repair or replace to the original user or consumer any portion of this product which proves to be defective due to materials or workmanship. At all times the manufacturer shall have and possess the sole right and option to determine whether to repair or replace defective equipment, parts, or components. The manufacturer has the option to inspect any product returned under warranty to confirm that the warranty applies before repair or replacement under warranty is approved. This warranty sets forth the manufacturer's sole obligation and purchaser's exclusive remedy for defective product. Return defective product to the place of purchase for warranty consideration.

WARRANTY PERIOD - PRODUCTS:

If, within the duration of product use by the original user, this product proves to be defective due to materials or workmanship, the product shall be repaired or replaced at the manufacturer's option, subject to the terms and conditions set forth in this warranty statement. Proof of purchase is required for warranty consideration. In the absence of suitable proof of the purchase date, the effective period of this warranty is 12 months from the product's date of manufacture.

LABOR, ETC. COSTS:

The manufacturer shall IN NO EVENT be responsible or liable for the cost of field labor or other charges incurred by any customer in removing and/or affixing any product, part, or component thereof.

PRODUCT IMPROVEMENTS:

The manufacturer reserves the right to change or improve its products or any portions thereof without being obligated to provide such a change or improvement for units sold and/or shipped prior to such change or improvement.

GENERAL TERMS AND CONDITIONS:

This warranty shall not apply to damage due to acts of God, normal wear and tear, normal maintenance services and the parts used in connection with such service, lightning or conditions beyond the control of the manufacturer, nor shall it apply to products which, in the sole judgment of the manufacturer, have been subject to negligence, abuse, accident, misapplication, tampering, alteration; nor due to improper installation, operation, maintenance or storage; nor to excess of recommended maximums as set forth in the instructions. Warranty will be VOID if any of the following conditions are found:

1. Product is used for purposes other than those for which it was designed and manufactured
2. Product not installed in accordance with applicable codes, ordinances, and good trade practices
3. Product connected to voltage other than indicated on nameplate or labels
4. Pump exposed to but not limited to the following: sand, gravel, cement, grease, plaster, mud, tar, oil, gasoline, solvents or other abrasive or corrosive substances
5. Pump has been used for pumping liquids above 120°F
6. Pump allowed to operate dry (liquid supply cut off)

DISCLAIMER:

Any oral statements about the product made by the seller, the manufacturer, the representatives, or any other parties do not constitute warranties, shall not be relied upon by the user, and are not part of the contract for sale. Seller's and the manufacturers only obligation, and buyer's only remedy, shall be the replacement and/or repair by the manufacturer of the product as described above. NEITHER SELLER NOR THE MANUFACTURER SHALL BE LIABLE FOR ANY INJURY, LOSS OR DAMAGE, DIRECT, INCIDENTAL OR CONSEQUENTIAL (INCLUDING, BUT NOT LIMITED TO, INCIDENTAL OR CONSEQUENTIAL DAMAGES FOR LOST PROFITS, LOST SALES, INJURY TO PERSON OR PROPERTY, OR ANY OTHER INCIDENTAL OR CONSEQUENTIAL LOSS), ARISING OUT OF THE USE OR THE INABILITY TO USE THE PRODUCT, AND THE USER AGREES THAT NO OTHER REMEDY SHALL BE AVAILABLE TO IT. Before using, the user shall determine the suitability of the product for his/her intended use, and user assumes all risk and liability whatsoever in connection therewith.

THE WARRANTY AND REMEDY DESCRIBED IN THIS LIMITED WARRANTY IS AN EXCLUSIVE WARRANTY AND REMEDY AND IS IN LIEU OF ANY OTHER WARRANTY OR REMEDY, EXPRESSED OR IMPLIED, WHICH OTHER WARRANTIES AND REMEDIES ARE HEREBY EXPRESSLY EXCLUDED, INCLUDING BUT NOT LIMITED TO ANY IMPLIED WARRANTY OF MERCHANTABILITY OR FITNESS FOR A PARTICULAR PURPOSE, TO THE EXTENT EITHER APPLIES TO A PRODUCT SHALL BE LIMITED IN DURATION TO THE PERIODS OF THE EXPRESSED WARRANTIES GIVEN ABOVE.

Some states and countries do not allow the exclusion or limitations on how long an implied warranty lasts or the exclusion or limitation of incidental or consequential damages, so the above exclusion or limitations may not apply to you. This warranty gives you specific legal rights, and you may also have other rights which vary from state to state.

**Effective July 1, 2023, due to an update in California law, the start date for product warranties will now be aligned with the date of delivery of the product. This change is for all Mainline products purchased on or after July 1, 2023 by California consumers. (California Legislative Information AB-2912)*



The Pump Authority.

INSTALLATION & OPERATION MANUAL BATTERY BACKUP SUMP PUMP SYSTEM Model: MLP72910

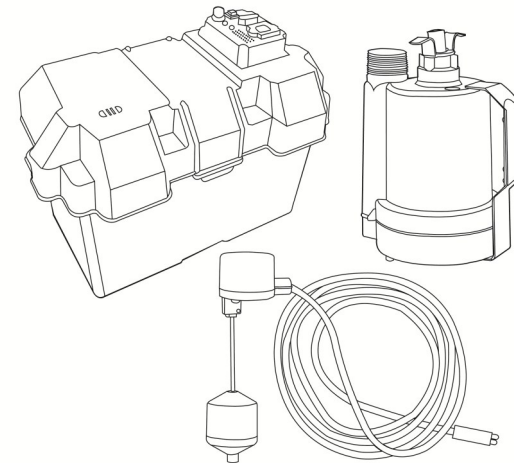

Safety Guidelines

Carefully read, understand and follow all safety instructions in this manual.

! This is the safety alert symbol. When you see this symbol, look for one of the following signal words.

⚠ DANGER Indicates a hazardous situation which, if not avoided, will result in death or serious injury.

⚠ CAUTION Indicates a hazardous situation which, if not avoided, could result in death or serious injury.

⚠ WARNING Indicates a hazardous situation which, if not avoided, could result in minor or moderate injury.

Safety Information

Read these warnings carefully. Know the application and limitations of this pump. Failure to follow these warnings could result in serious bodily injury and/or property damage.

⚠ DANGER RISK OF ELECTRICAL SHOCK. Disconnect and lockout power supply before removing old pump or installing or servicing this pump.

⚠ DANGER RISK OF ELECTRICAL SHOCK. This pump is supplied with a grounding conductor and grounding type attachment plug. To reduce the risk of electric shock, be certain that it is connected only to a properly grounded, grounding type receptacle. For added safety, it is highly recommended to connect this pump to a GFCI (Ground Fault Circuit Interrupter) outlet. Connect only to a receptacle that is adequately rated for the voltage and amperage of this pump

⚠ WARNING The installation of this pump must be in accordance with the National Electric Code (NEC), Uniform Plumbing Code (UPC), International Plumbing Code (IPC) as well as all applicable local codes and ordinances.

⚠ CAUTION Do not install this pump in any location classified as hazardous by the National Electrical Code, ANSI/NFPA70.

⚠ CAUTION Do not use this pump to pump flammable or explosive fluids such as gasoline, kerosene, etc. Do not use this pump in flammable or explosive environments. Use only with liquids compatible with pump component materials.

⚠ WARNING RISK OF ELECTRICAL SHOCK. This pump has not been investigated for use in swimming pool or marine areas.

⚠ WARNING RISK OF ELECTRICAL SHOCK. **DO NOT** use the power cord to remove or lower the pump into the basin. The cord may pull apart exposing bare wires which could cause a fire or electrical shock. Use the handle supplied with the pump for installing and removing the pump from the basin.

⚠ WARNING Do not run the pump dry. This pump relies on water for cooling. Running the pump dry can cause the pump to overheat and the possibility of burns to anyone that handles the pump. Running the pump dry will void the warranty.

⚠ WARNING Don't expose pump to freezing temperatures. Discharge lines exposed to freezing temperatures should be positioned with a downward slope to prevent freezing.

Replacement Parts

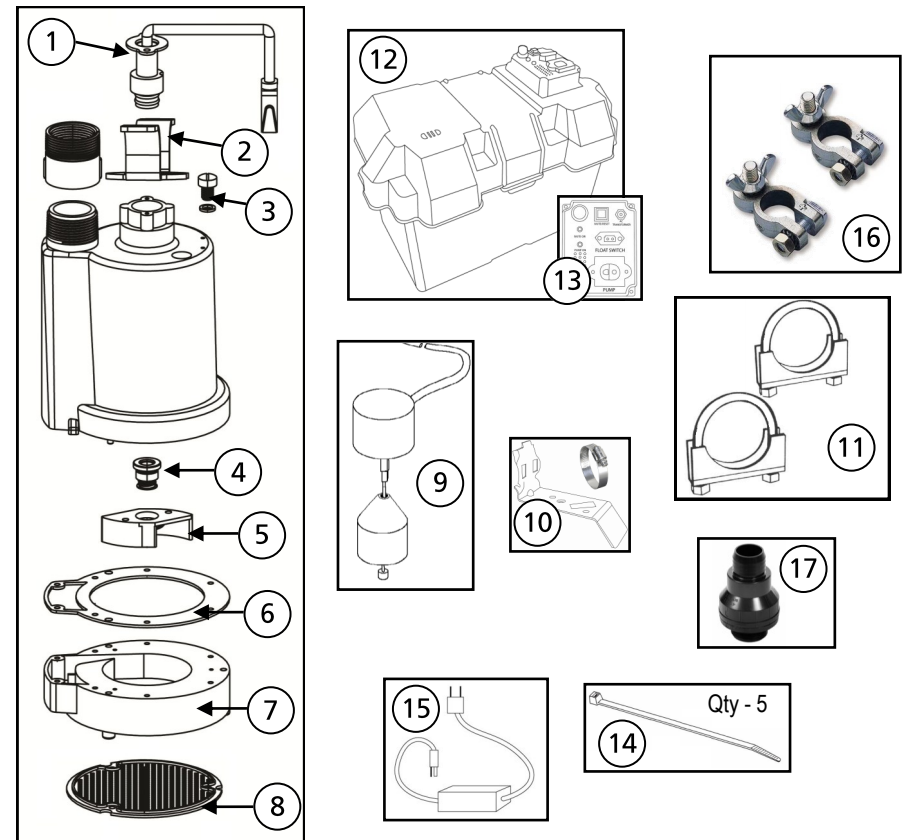

Ref #	Description	MLP72910
1	Power Cord	99158
2	Handle	99051
3	Oil Fill Plug with O-ring	99056
4	Shaft Seal	99057
5	Impeller	99060
6	Gasket	99062
7	Volute/Base	99067
8	Intake Screen	99073
9	Float Switch	92091
10	Vertical Float Switch Bracket & Clamp	99195
11	U-Bolt & Saddle Clamp Assembly	99462
12	Battery Box (Complete Unit)	99464
13	Control Panel (no cover)	99465
14	Cable Ties	Purchase Locally
15	AC Power Cord	99467
16	Battery Terminals (+ & -)	99460
17	Check Valve	99507

Troubleshooting

Problem	Possible Causes	How to Correct
Pump won't run.	Loose, corroded or reversed wire connections	Tighten, clean or reconnect if necessary
	Discharged battery	Charge battery
	Defective battery	Replace battery
Pump hums but won't run	Blown fuse	Replace with 20 amp fuse
	Float switch is stuck	Position float so it moves freely
	Battery is discharged below 10 volts	Fully charge battery
Pump cycles too often	Float switch positioned improperly	Reposition float switch
	Defective or missing check valve	Install or replace check valve
Pump runs but moves little or no water	Low or discharged battery	Fully charge battery
	Obstruction in pipe	Clear obstruction
	Discharge pipe height/length exceeds the capacity of the pump	Check performance section for capacity of this pump
	Defective check valve	Replace Check Valve if necessary

Performances

Height and/or piping restriction will reduce the pump output performance. It is recommended to use the same size or larger pipe as the pump discharge for optimum performance.

Model	Discharge Height	0'	5'	10'	15'	20'
MLP72910	Gallons Per Minute	23	22	18	13	8

Performance ratings are based on using a 27M, 12 volt deep cycle marine battery with a 100 Ah rating

Safety Information (continued)

- ⚠ WARNING** Do not use this pump for potable/drinking water. Use only in applications for which the pump is designed for.
- ⚠ WARNING** According to the state of California (Prop 65), this product contains chemicals known to the state of California to cause cancer and birth defects or other reproductive harm.
- ⚠ WARNING** All wiring must be performed by a qualified electrician.
- ⚠ WARNING** Keep hands clear of suction & discharge openings. To prevent injury, never insert fingers into pump while it is plugged in.
- ⚠ CAUTION** Do not handle this pump with wet hands or while standing on wet or damp surfaces or in water.
- ⚠ DANGER** Never touch any electrical device, including this pump and charger, when it is touching water, in water, or even in a moist environment. Always unplug (disconnect the electricity) when working on or installing the unit.
- ⚠ DANGER** **RISK OF ELECTRICAL SHOCK.** Do not plug in or unplug the AC transformer while standing on a wet floor. If basement floor is wet, disconnect the power before walking on the floor.
- ⚠ CAUTION** Battery acid is corrosive. Do not spill on skin, clothing, or parts of this system. Wear gloves and eye protection when handling the battery.

Description

This 12 volt backup pump system is designed to remove water from residential sump basins. IT IS NOT INTENDED TO REPLACE REGULAR PRIMARY SUMP PUMPS. This pump will provide backup protection in the event of a household power failure or primary pump malfunction.

Specifications

Model	MLP92910
HP	n/a
Volts	12 volt DC
Amps	13 Amps
Hz	n/a
Phase	n/a
Discharge Size	1-1/4" or 1/2" NPT
Max. Solids Handling	1/8"
Liquid Temperature Range	32°F - 120°F
Cord Length	10'
Switch Type	Vertical
Pump Housing Construction	Thermoplastic
Pump Base Construction	Thermoplastic
Impeller	Thermoplastic
Motor Shaft	Stainless Steel
Shaft Seal	Carbon/Ceramic/Stainless Steel
Fasteners	Stainless Steel
Shut off head	21'
Max. PSI	9.0
Battery Requirement	12 volt Deep Cycle
Battery Charger	2 Amp
Low Voltage Cutoff	10 volts

Operation

1. Once your installation and wiring connections are complete, unplug or disconnect the power to the primary pump.
2. Fill the basin using buckets or a hose. Observe the float switches to make sure they are positioned properly when the basin is filling. Fill the basin until the backup float activates the alarm.
3. Make any necessary adjustments to the float(s) and/or pumps at this time.
4. When the power fails or when there is a problem with the primary pump, the back-up pump will automatically start. The back up pump will operate for many hours intermittently. During prolonged periods of power outage the pump may stop pumping when the battery voltage drops below 10 volts. When this happens the alarm will sound signaling that the voltage is too low to operate the pump.
5. This unit is equipped with a 2 amp charger. It will charge a discharged battery at a rate of 2 Ah (Amp hours). Once the battery reaches a full charge, the charger will gradually reduce the charge rate. It will also maintain a charged battery by periodically checking the voltage of the battery.
6. The charger is equipped with over charge protection. I will not let the battery become over charged.

Installation (continued)

Electrical Connections

1. If necessary, attach the provided battery terminals to the battery. (Many deep cycle marine batteries come with a threaded post terminal built in.) **NOTE:** The provided battery terminals are labeled (+) positive and (-) negative. Make sure the terminals are connected to the proper terminal on the battery. Place the battery in the battery box.
2. Connect the battery lead wires from the control panel to the corresponding terminals on the battery. Connect the red (+) positive lead to the positive battery terminal and tighten the wing nut. Connect the black (-) negative lead to the negative battery terminal and tighten the wing nut. Secure the battery box cover to the lower case.
3. Next connect the pump power cord, the float switch and the AC adapter to the corresponding terminals on the control panel. Make sure they are fully seated in the terminals.
4. Plug the AC adapter into the wall outlet and turn the power back on.
5. If your battery is fully charged you will notice a green light on the AC adapter. If the battery is not fully charged a red light will indicate that the battery is charging. Once fully charged, the light will change to green.

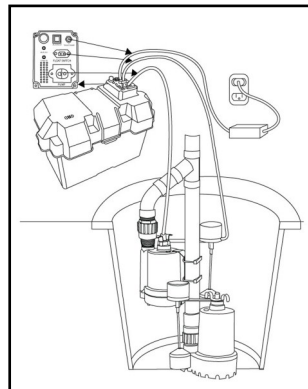
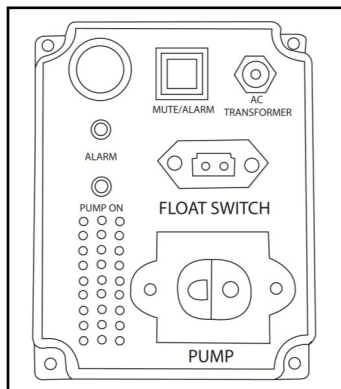

6. Once all connections are made, press the "MUTE/ALARM" button on the control panel until the "ALARM" light illuminates. This indicates that the alarm will sound once the pump is activated. To mute the alarm, press the "MUTE/ALARM" button on the control panel until the "ALARM" light turns off.
7. Test the float switch and pump by lifting and holding the float. The alarm will sound and the "PUMP ON" light on the control panel will illuminate. The pump should start after lifting the float. If it does not run, check your connections and retry.

Battery Requirements

This system is designed to work with 12 volt, lead-acid deep cycle marine / RV batteries. Either a flooded cell (serviceable or maintenance free) or sealed AGM battery are acceptable. Although most deep cycle batteries will work with this pump, it is recommended to use a battery with a minimum 90 amp-hour rating and a 175 minute reserve capacity or larger. Avoid using automobile batteries as these types of batteries are not intended to be charged/discharged for extended periods of time. The Battery case will hold size 24 or 27 batteries.

During prolonged periods of power failure or in an emergency, your automobile battery may be used. Make sure to replace the deep cycle battery as soon as possible as the automobile battery will be quickly ruined by the continuous charge/discharge cycles.

Carbon Monoxide (CO) Detectors

All backup pump systems that use lead acid batteries, regardless of brand, give off gaseous by-products when the battery is charging. Some of these by-products can cause a carbon monoxide (CO) detector to give a false alarm. When installing this system, position the battery as far away from the CO detector as possible. **DO NOT** move or remove CO detectors from their original location. Always follow the instructions that accompany your CO detector.

If your CO detector alarm sounds, take the following actions.

1. Take immediate action for personal safety as outlined in the CO detector manual.
2. Contact the appropriate utility agency to determine if the CO is coming from your furnace, water heater or other appliance that uses natural gas

If it's determined that a charging battery is causing the CO detector to activate, contact the manufacturer for recommendations on how to alleviate the problem.

Installation (continued) Installation

NOTE: Install this system when the primary pump will not be required.

1. Start by finding the water level at which your primary pump starts. Mark this point on the discharge pipe with a pencil or marker.
2. **NOTE:** If your existing discharge pipe is metal or flexible tubing it will need to be replaced with Schedule 40 PVC or ABS pipe.
3. Drain as much excess water from the sump pit as possible.
4. When the basin has been drained, turn off the power to the outlet / pump to avoid the risk of electrical shock.
5. Before removing the primary pump, make sure the discharge pipe is properly supported to prevent it from collapsing.
6. If your installation uses a flexible pipe coupling with clamps, simply disconnect the coupling and remove the pump. If a flexible coupling is not used, cut the pipe as close to the floor as possible using a hacksaw and remove the pump from the basin **NOTE: BE PREPARED FOR WATER TO LEAK FROM THE PIPE WHEN CUTTING.** Keep tools and components of this system away from the work area when cutting pipe. If any components get wet, make sure they are dry before installing.
7. If your primary pump does not have a check valve in or near the pump discharge, install one at this time (not provided). It is necessary to have a check valve installed on both the back up pump and on the primary pump. The primary pump check valve must be located below the junction of where the back up and primary piping meet. This is to prevent backflow from the back-up pump when it is running.

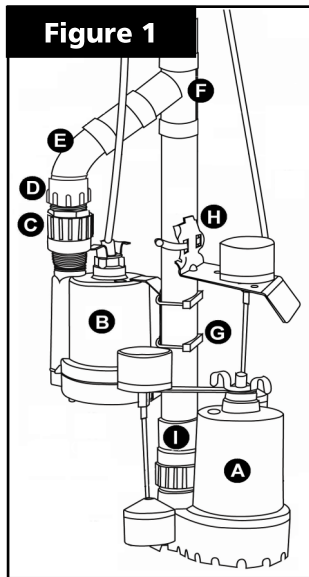

- Figure 1**
- A. Primary Pump
 - B. Back up Pump
 - C. Check Valve
 - D. Female Adapter
 - E. 45° Street Elbow
 - F. Wye fitting
 - G. U-Bolts & Clamps
 - H. Float Switch Clamp
 - I. Primary pump check valve (not included)

8. Attach the back-up pump to the primary discharge pipe using two U-Bolts, clamps, washers and nuts (G). Position the pump so it is located near the water level that was marked in Step 1. Tighten nuts using a 10mm socket or adjustable wrench. **DO NOT** over tighten. **NOTE:** Make sure the U-bolts are properly seated in the recessed areas on the pump mounting bracket. (The pump mounting bracket comes pre-attached to the pump).

Installation (continued)

9. Thread the check valve (C) onto the discharge of the back-up pump
10. Plumb the back-up pump to the primary pump piping using a 1-1/2" Female Adapter (D), 45° Street Elbow (E) and a Wye fitting (F). It is highly recommended to do a "dry fit" before permanently gluing the pipe and fittings together. Place the assembly in the basin to make sure that it fits and that the primary float switch operates freely before permanently gluing the pipe and fittings together.
11. Remove the assembly from the basin and glue all fittings.
12. Next, secure the float switch to the discharge pipe using the provided clamp. See figure 2 below for proper installation. **DO NOT** fully tighten the clamp at this time. Leave it a bit loose so you can adjust the position of the float in the next steps.
13. After the float switch has been attached to the discharge pipe, place the entire assembly in the basin. Make sure the primary pump float switch will operate freely and not contact the sides of the basin. Connect the pump assembly to the discharge pipe. Use either a flexible coupling with clamps or a solvent weld PVC or ABS coupling.

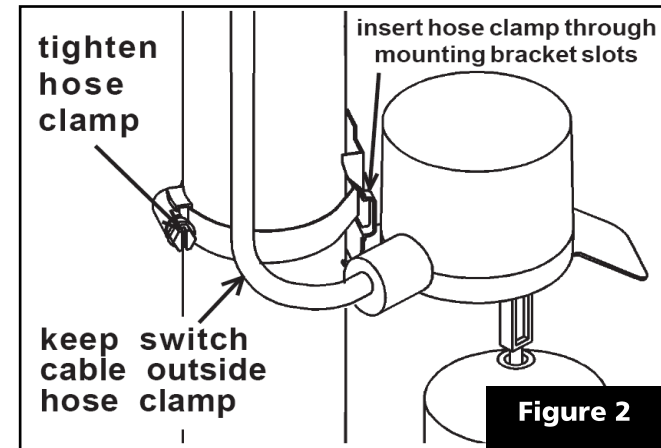

Switch Installation

Position the Vertical Float Switch on the discharge pipe so it will turn on when the water level rises above the start level of the primary pump. Make sure the "on" level does not exceed the top of the basin. It is recommended to keep at least a 2" clearance from the top of the basin. You can adjust the "off" level of the vertical float by moving the grommet up or down on the vertical float rod. Once positioned properly, completely tighten the float switch clamp.

NOTE: There are many different options for assembling this unit. The instructions above represent one of the most common installations. Your installation may vary. If you have a very shallow basin, mounting the back-up pump above the primary pump may not be feasible. You may also position the pump on bottom of the basin. Make sure the back up pump is positioned so that it won't interfere with the primary pump operation.